

UNIVERSITY OF CALIFORNIA

Los Angeles

An integrated approach to scale up the market penetration of low carbon technologies in
developing countries and water scarce regions

A dissertation submitted in partial satisfaction of the
requirements for the degree of Doctor of Environmental Science and Engineering

by

Michelle Angela Thompson

2016

© Copyright by
Michelle Angela Thompson
2016

ABSTRACT OF THE DISSERTATION

An integrated approach to scale up the market penetration of low carbon technologies in developing countries and water scarce regions

by

Michelle Angela Thompson

Doctor of Environmental Science and Engineering

University of California, Los Angeles

Professor Michael K. Stenstrom, Chair

Water scarcity is a global challenge that stifles social and economic growth. There is a growing concern to examine the water-energy nexus to understand the importance of applying energy and water interactions to technology. In developing countries there are many communities that live off-grid in remote region with no access to electricity or clean water. Additionally, there are developed countries that are located in regions with electricity but no access to clean water. Recent developments in renewable energy technology and energy policies have greatly reduced the costs of renewable energy making them more attractive and affordable. The purpose of this dissertation is to evaluate the main barriers to deploying renewables to non-Organization for Economic Co-operation and Development (non-OECD) countries and member countries of the Organization for Economic Co-operation and Development (OECD). This dissertation examines the potential of renewable desalination technology systems across emerging countries. The findings of this research can serve as the basis for investors interested in entering this market. The combined chapters seek to address potential problems regarding the costs, methods, and tools required for the implementation of the appropriate water purification technologies for off-grid, community scale infrastructures.

This dissertation of Michelle Angela Thompson is approved.

Jennifer Ayla Jay

Donald Robert Kendall

Charles J. Corbett

Michael K. Stenstrom, Committee Chair

University of California, Los Angeles

2016

To my parents Guy Thompson and Carmela Song

“If we could ever competitively, at a cheap rate, get fresh-water from salt-water it would be in the long-range interests of humanity, which would really dwarf any other scientific accomplishments. I am hopeful that we will intensify our efforts in that area.”

-JFK, 1961

Table of Contents

ABSTRACT OF THE DISSERTATION	ii
ACKNOWLEDGMENTS	ix
VITA.....	x
1. Introduction.....	1
1.1 Water-energy nexus	1
Figure 1. Map of projected water stress countries by 2040	2
1.2 Motivation.....	3
1.2.1 Literature Review.....	7
1.2.2. Desalination	7
Table 1. Common desalination technologies.....	8
Table 1.1. Characteristics of different desalination processes.....	9
1.2.3 Energy requirements for desalination	9
Table 1.2. Energy requirements and greenhouse gas emission for different desalination processes .	10
1.2.3.2 Enhanced system design	11
1.2.4 Thermal Processes	11
Table 1.3. Solar distillation plants worldwide	12
1.2.5 Membrane Processes.....	13
1.2.6 Reverse osmosis.....	14
Figure 1.1. RO Schematic.....	14
1.3 Desalination and renewables.....	15
Table 1.4. Reverse osmosis plants worldwide driven by photovoltaic cells	16
1.4 Membrane Distillation	17
1.5 Comparing thermal technologies	18
1.6. Desalination and the environment	20

1.8 Renewable sources to utilize.....	26
Table 1.5. Comparison of renewable energy resources	26
1.8.2 Photovoltaic systems.....	29
1.9 PV-RO system economics	30
1.9.1 Social and cultural barriers to technology adoption	30
1.9.2 Organization of the Dissertation	31
References.....	34
2. A Critical Review of Water Purification Technology Appropriate For Developing Countries: Northern Ghana as a Case Study	36
2.1 Introduction.....	36
2.2 General Overview	37
2.3 Ghana’s water crisis: General context and overview.....	38
2.4 Water supply in rural areas of Ghana	39
2.5 Treatment Options	39
2.6 Personal Treatment Options.....	40
2.7 On-site Water treatment plants	43
2.8 Systematic Evaluation of Technologies.....	44
Table 2. Assessment of personal and on-site water technologies	45
2.9 Criteria Ranking.....	46
2.9.1 Methodological Limitations.....	46
2.9.2 Discussion	49
2.9.3 Conclusion	52
References.....	53
3. Technical and economic evaluation of an off-grid solar desalination system in Myanmar	55
3.1 Introduction.....	55
3.2 Overview of Desalination	56
3.3 Modelling Assumptions.....	58
3.4 System design	59
Figure 3. Solar desalination flow diagram.....	60
3.5 Capital expenditure	60

Table 3.1. Capital costs of system	60
3.5.1 Construction and permits	61
3.5.2 Distribution	61
3.5.3 RO system equipment.....	62
3.5.4 Photovoltaic installation and storage	62
3.6 Operating expenditures (OpEx)	63
Table 3.2. Annual operational costs of system (in USD)	64
3.6.1 Pre-treatment and membrane replacement.....	64
3.6.2 Brine disposal.....	65
3.6.3 Photovoltaics and storage costs	65
3.6.4 Labor costs	66
3.7 Discussion	66
3.8 Conclusion	68
4. Policy strategies and approaches for financing photovoltaic-powered water purification and desalination units	72
4.1 Introduction.....	72
Methodology for selecting water-stressed regions	73
4.2 Key variables for the four regions	74
Table 4. Socio-economic data for the three regions	75
4.3 Background of Singapore’s water efficiency scheme.....	76
4.4 Optimization and performance of an off-grid solar-powered water purification system	77
4.5 Materials and Methods.....	77
4.5.1 Photovoltaics.....	77
4.5.2 Study Site	78
4.5.3 System configuration and operation	78
Figure 4. Schematic diagram of the experimental setup.....	80
4.5.4 Analytical Methods.....	80
4.6 Costs.....	81
4.7 Results and Discussion	82
4.7.1 General Parameter and Ions	82

Table 4.1. Average Water Quality of Kent Ridge Park Pond Before and After Treatment Compared to Environmental Protection Agency (EPA) and World Health Organization (WHO) standards.....	83
Table 4.2 Ion concentrations of the influent and effluent water.	84
4.7.2 MS2 bacteriophage virus removal	84
Table 4.3 Bacteriophage MS2 log removal in different parts of the system.	84
4.8 Experimental Limitations.....	85
4.9 Case studies for desalination in Oman and Ghana.....	86
4.9.1 Desalination in Oman	86
4.9.2 The complications of financing Ghana’s first desalination plant	88
4.9.3 Comparative economics of solar powered RO plants for water-stressed countries.....	89
Figure 4.1 Possible combinations of renewable energy desalination systems.....	91
Table 4.4 Renewable Energy Coupling Options.....	91
4.10. Renewable energy hybrids	92
Table 4.5 Processes and their percentage costs	92
4.11 Results and Discussion	93
4.11.1 Policy overview and recommendations	93
Table 4.6 Fiscal Incentives to Encourage Deployment of Renewable Desalination Technology	94
Table 4.7. Public finance to Encourage Deployment of Renewable Desalination Technology	95
Table 4.8. Regulations to Encourage Deployment of Renewable Desalination Technology	96
4.12 Conclusions.....	97
5. Conclusions and Remarks.....	100

ACKNOWLEDGMENTS

I would like express my deepest gratitude to my parents Carmela Song and Guy Thompson. You have instilled in me a desire to be curious and take risk in everything I do. Thanks for giving me the freedom to study abroad and travel. I am grateful to have been taken on weekend trips discovering the beauty of the Bay Area.

I also wish to extend my appreciation to my UCLA advisor Dr. Michael Stenstrom. He has been a compassionate role model, mentor, and friend who have helped me become a better writer, scientist, and person. I will remember our trip to the Korea conference.

In addition, thanks to Dr. Eric Hoek for asking me to be part of the UCLA Fiji team. He has been an aspirational entrepreneur and professor who instill in me the many hats a scientist can have.

Thanks to the Solar Energy Research Institute of Singapore (SERIS) for my internship as a project manager. This was a growing experience and a great challenge where I proved to myself I could be independent alone.

Many thanks to extended committee members for their guidance, support and encouragement during my PhD study. Also, to Dr. Keith Stolzenbach who helped me with academic advising, calming me down when I was stress and wanted to quit, and taught me more about mass balance than I wanted to know.

Thank you to Myrna Gordon who helped me with logistics when I traveled to conferences.

I gratefully acknowledge my peers and my research assistants at UCLA, the National University of Singapore, and National Taiwan University.

Thank you to my main support system through my graduate career: my dear friends Rita Chang, Raven Faavae, and Vince Rabsatt who helped me emotionally and spiritually.

Finally, I acknowledge the funding from UCLA Graduate Division, Solar Energy Research Institute of Singapore, U.S. Department of Energy, and the National University of Taiwa

VITA

2002-2007 B.S. Marine Biology
University of California of Los Angeles

2010-2011 M.P.A. Environmental Science and Policy
Columbia University

2012-2016 (expected) D. Env Environmental Science & Policy
University of California of Los Angeles

PUBLICATIONS

Thompson, M. "Policy strategies and approaches for financing photovoltaic-powered water purification and desalination units." (In press) *International Journal of Water Resources and Environmental Engineering*

Thompson, M. & You Jiing-Yun, Gene. "Financing mechanisms to increase investment in Asia's hydropower." (In press) *Natural Resources Forum, a United Nations Sustainable Development Journal*

Thompson, M., "Technical and economic evaluation of an off-grid solar desalination system for Southeast Asia: Myanmar Case Study" (In press) *Journal of Water Supply: Research and Technology – AQUA*.

Thompson, M. "A critical review of purification technology appropriate for developing countries: Northern Ghana as a case study." *Desalination and Water Treatment* (May 2014).

Fiji News, UCLA students help Fijian villages develop water infrastructure, group interview (2012)

“Corporate Environmental Social Governance & Sustainability and Corporate Responsibility Reporting-Does it Matter?’ Published by Governance and Accountability Institute, New York, NY, 90024. Primary Author/Researcher, Sept. 2011.

Featured in the Ghana Government Portal “U.S. Delegates Visit Ghana,’ Jul. 2011.

Featured ‘Climate Change Interview’ on Ghanaian eTV News, Jul. 2011.

Journalist for U.S.C. U.S.-China Institute. Authored: ‘China Goes Green?’ Mar. 2009; ‘What Lies Beneath, The Treasures Untold,’ May 2009.

PRESENTATIONS

Thompson, M.A. ‘Assessing the feasibility and performance of a stand-alone solar-powered water filtration system for rural villages in Southeast Asia,’ presented at the 7th Desalination for Clean Water and Energy, Palermo, Italy; May 10-14, 2015.

Thompson, M.A. ‘Technical and economic evaluation of an off-grid solar desalination system in Myanmar,’ presented at the 7th International Young Water Professional Conference, Taipei, Taiwan; Dec. 7-11, 2014.

Thompson, M.A. ‘Technical and economic evaluation of an off-grid solar desalination system in Los Angeles,’ presented at the Research Symposium on Energy, Environment, and Business Conference, Dubai, United Arab Emirates, Nov. 15-16, 2014.

Thompson, M. A. ‘A critical review of water purification technology appropriate for developing countries: Northern Ghana as a case study,’ presented at the 5th Annual IWA-ASPIRE Conference, Daejeon, South Korea, Sept. 8-12, 2013.

‘Sustainable Fisheries for Ghana Policy Briefing,’ presentation & policy brief; Accra, Ghana

FELLOWSHIPS & AWARDS

Edward A. Bouchet Graduate Honor Society, Awarded to 1% of all UCLA PhD candidates, Yale University, 2016

The Eugene V. Cota-Robles Fellowship, 2012-2016

Dr. Ursula Mandel Fellowship, 2014

Malcolm R. Stacey Fellowship, 2014

National Science Foundation UCLA Competitive Edge Summer Fellowship, 2012

National Science Foundation Integrative Graduate Education Research Traineeship on Clean Energy for Green Industry, 2013

1. Introduction

1.1 Water-energy nexus

Present day water and energy systems are interdependent. Water is used in all phases of energy production and electricity generation. Energy consumption is important in the development of countries. Energy is required to extract, convey, and deliver water for human consumption and to treat wastewater. The water-energy nexus is the relationship where energy production depends on water. It is used in power generation, for cooling thermal power plants, in the extraction, transport, and processing of fuels; and in irrigation to grow biomass feedstock crops. Conversely, energy is vital to providing freshwater, needed to power systems that collect, transport, treat, and distribute.

Furthermore, energy is a critical parameter of economic and industrial development. In developing nations there is little access to energy. There are still remote areas in the world that are completely off-grid, and have no connection to electricity. Additionally, there are grid-connected cities that are striving to utilize renewable energy.

Climate change will affect water availability, and water availability affects the water-energy nexus (Energy, 2014). In the near decades, climate change may alter water availability by fluctuation in temperatures, increasing variability, varying precipitation patterns, and extreme weather. Shifts in temperature and precipitation patterns are predicted to impact regional variations in water availability for hydropower, biofeed production, thermoelectric generation, and other energy demands. Alternatively, increases in temperature have the potential to increase electricity demand and decrease the efficiency of thermoelectric generation (Energy, 2014).

The water-energy nexus is fundamental to environmental policy in the United States in terms of climate change and energy security.

Figure 1. Map of projected water stress countries by 2040

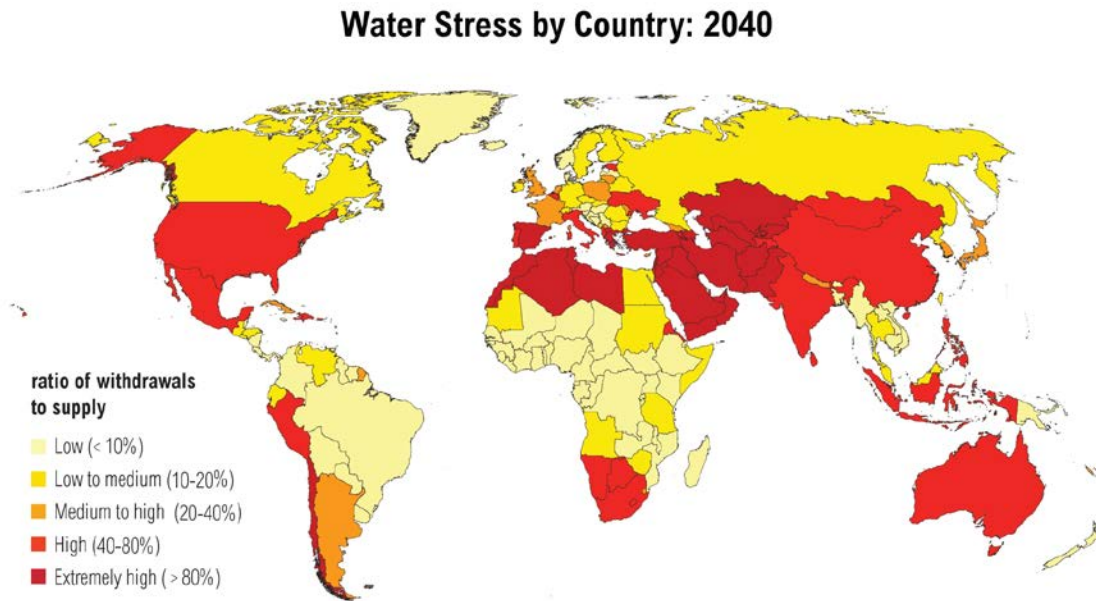

NOTE: Projections are based on a business-as-usual scenario using SSP2 and RCP8.5.

For more: ow.ly/RiWop

 WORLD RESOURCES INSTITUTE

1.2 Motivation

The growing scarcity of freshwater is a global problem. Water issues will affect developing countries and industrialized nations in the coming decades. Sectors such as agriculture, hydroelectric, thermoelectric generation, and municipal water supplies will feel the pressure of water scarcity. Globally, about 1.2 billion people do not have access to clean drinking water causing millions of people to die annually—3,900 children a day--from diseases transmitted through unsafe water or human excreta (World Health Statistics, 2010). This number is expected to increase due to population growth (United Nations World Water). It is estimated that the population will increase over the decade with about 50% in Africa, 25% in Asia, 14% in the USA, and 2% negative in Europe (Eltawil, Zhengming, & Yuan, 2009). The increase in the world population will be concentrated mainly in most of the developing countries and particularly in Africa, causing severe water shortages (Eltawil et al., 2009). As a result, 40% of the world populations are afflicted with inadequate access to water, with emphasis on people who live in remote rural regions (Eltawil et al., 2009).

There is inequity in access to clean water and sanitation. Impoverished regions severely lack water and sanitation services. In these regions communities are afflicted with diarrheal disease caused by exposure to pathogenic microbes through various routes (Montgomery & Elimelech, 2007). At the beginning of 2000, two-fifths of the world's population (2.4 billion people) lacked access to improved sanitation facilities. The majority of these people live in Asia and Africa, where fewer than half of all

Asians have access to improved sanitation. Furthermore, sanitation coverage in rural areas is less than half than in urban locations. In Africa, Asia, Latin America, and the Caribbean, nearly 2 billion people in rural areas have no access to improved sanitation facilities.

Polluted water is estimated to affect the health of more than 1.2 billion people, and to contribute to the death of an average of 15 million children every year (UNEP, 2008). Diarrhea is one of the leading causes of morbidity and mortality in less developed countries, especially among children aged less than five years (Fewtrell et al., 2005). Nearly 60% of infant mortality is linked to infectious diseases, most of them water and sanitation related. Additionally, diarrhea has been linked to secondary health impacts, such as malnutrition and reduced cognitive function in children (Montgomery & Elimelech, 2007). Thus, millions suffer from preventable illnesses and die every year.

The adverse effects of unclean water extend beyond the unequivocal consequence of disease (Montgomery & Elimelech, 2007). The collection of water, primarily the responsibility of women and children, represents an additional burden. For example, in a developing country it takes up to 6 hours each day to search for water. As a result, time spent in search of water forces children to miss school and women to forgo potential opportunities to engage in small business endeavors (Montgomery & Elimelech, 2007).

Safe drinking water and basic sanitation are key elements of the Millennium Development Goal 7 of the United Nations initiative. It aims to halve, by 2015, the proportion of the population without sustainable access to safe drinking water and basic sanitation (United Nations, Millennium Development Goals Report, 2011). This initiative is a priority because access to clean water and sanitation is strongly correlated to economic productivity and socio-economic development. Energy, agricultural-yield, and industrial output affect the economies of both developing and industrialized nations (Shannon et al., 2008). Consequently, in both nations contamination is finding its way into water supplies from human activity: from traditional compounds to emerging micro-pollutants.

According to the Intergovernmental Panel on Climate Change (IPCC) Fifth Assessment Report (AR5) communities around the world will face common and significant water-related risks. The report stated that each degree of warming is projected to decrease renewable water resources by at least 20 percent for an additional 7 percent of the global population. The IPCC report states that by 2100, millions of people in Asia will be displaced by coastal flooding. And small island states will be particularly vulnerable to sea level rise.

In addition to the UNEP, the NAMA Registry is a publicly available online platform operated by the United Nations Framework Convention on Climate Change (UNFCCC) Secretariat. Its purpose is to increase opportunities for implementation of and recognition for Nationally Mitigation Actions (NAMAs) in developing countries.

In the coming decades, water scarcity may cause drought, famine, population migration, and even civil wars. Thus, expanding global access to clean drinking water and healthy sanitation will help save lives and improve public health for all.

1.2.1 Literature Review

1.2.2. Desalination

In response to increasing fresh water demand, population growth, and rapid industrialization, society is facing new challenges to meet the water demand and energy requirements for the needs of future generations (Gude et al., 2010). As a result many local governments are deciding to turn to a more unconventional water supply, seawater desalination. The supply of freshwater requires energy, a very high amount when coming from seawater. Typically, desalination plants are powered by energy derived from combustion of fossil fuels (Gude et al., 2010). A more recent approach to utilizing seawater is to sustainably couple innovative desalination technologies with renewable energy sources.

A new wave of literature is being published on the necessity to develop alternatives to replace conventional energy sources used in desalination with renewables, innovative low-energy technologies, and process hybridizations in order to reduce the energy requirements for desalination that is need by developing countries (Gude et al., 2010). This literature review discusses desalination technologies and utilizing solar photovoltaic modules and off-grid water purification systems for developing countries.

About 80% of the world's desalination capacity is provided by two technologies: multi-stage flash (MSF) and reverse osmosis (RO) (Eltawil et al., 2009); (Khawaji et al., 2008). The dominant processes of MSF and RO are 44% and 42% of worldwide

capacity, respectively. The MSF process represents 93% of thermal process, while RO represents more than 88% of membrane processes (Eltawil et al., 2009).

The two basic technologies used for desalination can be categorized into two kinds: (1) phase-change/thermal and (2) membrane separation. Examples of phase-change processes include multi-stage flash (MSF), multiple effect boiling, vapor compression, freezing, humidification/dehumidification and solar still. In contrast, membrane based processes include reverse osmosis (RO), membrane distillation (MD) and electrodialysis (ED) (Charcosset, 2009).

Table 1. Common desalination technologies (Einav, Harussi, & Perry, 2003).

Reverse osmosis (RO)	Membrane processes, the most common in use. A semi-permeable membrane separates two solutions of different concentrations.
Electrodialysis (ED/EDR)	Membrane processes. A bundle of membranes is placed between two electrodes and electric field is induced. It is suitable for brackish water and for the remediation of polluted wells.
Multi stage flash (MSF)	Evaporation processes, in combination with power stations. The system includes a series of compartments. The flow of hot water into a compartment in which there is low pressure results in the evaporation of part of the water.
Multi stage distillation (MED)	Evaporation processes, based on the cycle of latent heat when generating steam, usually used in combination with power stations
Vapor compression distillation (VCD)	Evaporation processes based on the principle of a heat pump. Repeated cycles of condensation.

Table 1.1. Characteristics of different desalination processes.

Characteristic	Phase Change	Non-phase change	Hybrid
Nature	Thermal process: MED, MSF, MVC, TVC (evaporation and condensation)	Pressure/concentration gradient driven: RO (membrane separation), ED (electrochemical separation)	Thermal + membrane: membrane distillation, MSF/RO, MED/RO
Membrane pore size	—	0.1-3.5nm	0.2-0.6 micron
Feed temperature	60-120°C	<45°C	40-80°C
Cold water stream	May be required	—	20-25° C
Energy	Thermal, mechanical	Mechanical, electrical	Thermal, mechanical
Product quality	<20 ppm	Potable, < 500ppm	High quality distillate, 20-500ppm

1.2.3 Energy requirements for desalination

Desalination processes require vast amounts of energy to separate salt from the seawater. Energy is a significant cost in the economics of desalinating water. The largest concern with the increasing desalinated water supply is the environmental cost through usage of fossil fuels. It is estimated that for the creation of 22 million m³ per day it necessitates 203 million tons of oil per year. For saline water sources,

the lowest theoretical energy required for desalination to produce freshwater is 0.706 kWh/m³. The energy requirements for seawater desalination using thermal-based technologies are on the order of 7-14 kWh/m³ when compared to 2-6 kWh/m³ for membrane-based technologies (Subramani et al., 2011). Furthermore, the energy requirements are lower for RO is the highest cost component as a result to the high-pressure pumps. The costs of pumps represent more than 40% of the total energy costs.

Table 1.2. Energy requirements and greenhouse gas emission for different desalination processes

Process	MSF	MED	RO	ED
Thermal Energy	250-300	150-220	–	–
Electrical Energy	3.5-5	1.5-2.5	5-9	2.6-5.5
GHG (kgCO ₂ /m ³ H ₂ O)	24	19.2	8.6	5.3

To address greenhouse gas emission and energy consumption, researchers and engineers have stated the critical need to accelerate energy minimization approaches and rapidly develop renewable energy alternatives (Charcosset, 2009) (Subramani et al., 2011). This section explains the factors that have an vital role in minimizing energy usage in desalination processes, enhanced system design, high efficiency pumping, energy recovery, advanced membrane materials, and innovative technologies.

1.2.3.2 Enhanced system design

In the past decade, the design and configuration of membrane units have been modified from a two-stage system with six elements per pressure vessel to single-stage configurations. The former RO configurations resulted in a high feed and concentrate flow, which reduced concentration polarization. The newer designed single-stage configuration for high salinity feed water can use up to seven or eight elements per pressure vessel. The pressure drop reduction in using a single-stage instead of a two-stage system was shown to result in a 2.5 (Subramani et al., 2011).

1.2.4 Thermal Processes

Distillation is the process of separating solutes using evaporation and condensation. Three most common types of distillation are multi-effect distillation (MED), multi-stage flash (MSF), and vapor compression. MSF is commonly used in the Middle East: Saudi Arabia, the United Arab Emirates, and Kuwait, and accounts for 40% of the world's desalination capacity (Eltawil et al., 2009). An MSF process consists of a set of stages at successively decreasing temperature and pressure. A unique feature of MSF systems is bulk liquid boiling. This alleviates problems with scale formation on heat transfer tubes.

Previously, distillation technologies were preferred because of the lower reliability of earlier membrane technologies. MED is a distillation process where the feed water is heated by steam in tubes. MED is the low temperature thermal process of obtaining fresh water by recovering the vapor of boiling seawater in a sequence of

vessels. Each vessel is an effect and has a lower temperature than the previous vessel. Thus, the temperature of the condenser is not high enough to heat the saltwater in the vessel but can heat the subsequent vessel at a lower pressure. The disadvantage of MED is that it operates at high temperatures that increase corrosion and scale formation.

In MSF distillation, the water is heated under pressure, which prevents it from vaporizing while being heated. The water is then moved into separate chambers at lower temperature where it can vaporize far away from the heating pipes, which avoids scaling. Lastly, vapor compression increases the water temperature, which allows for heat recycling. The compressor can be driven by steam (thermal vapor compression) or by a diesel engine or motor (mechanical vapor compression).

Currently, the majority of new desalination plants now use membrane technologies; specifically reverse osmosis (RO). Table 1.3 shows the location of the solar distillation plants, type of solar collector mechanism, and capacity.

Table 1.3. Solar distillation plants worldwide; (García-Rodríguez, 2002)

Plant location	Desalination process	m ³ /d	Solar collectors
La Desired Island, French Carribean	ME, 14 effects	40	Evacuated tube
Abu Dhabi, UAE	ME, 18 effects	120	Evacuated tube
Kuwait	MSF, RO	25, 20	Solar electricity generation
Kuwait	MSF, auto regulated	100	Parabolic trough
La Paz, Mexico	MSF, 10 stages	10	Flat plate + parabolic trough
Arabian Gulf	ME	6000	Parabolic trough

Al-Ain, UAE	ME, 55 stages; MSF, 75 stages	500	Parabolic trough
Takami Island, Japan	ME, 16 effects	16	Flat plate
Margarita de Savoya, Italy	MSF	50-60	Solar pond
El Paso, Texas	MSF	19	Solar pond
Lampedusa Island, Italy	MSF	0.3	Low concentration
Islands of Cape Verde	Atlantis “Autoflash”	300	Solar pond
University of Ancona, Italy	ME, TC	30	Solar pond
PSA, Almeria, Spain	ME, heat pump	72	Parabolic trough
Gran Canaria, Spain	MSF	10	Low concentration
Area of Hzag, Tunisia	Distillation	0.1-0.35	Solar collector
Safat, Kuwait	MSF	10	Solar collector
Near Dead Sea	MED	1000	Solar pond
Berken, Germany	MSF	20	—

1.2.5 Membrane Processes

Microfiltration (MF) and ultrafiltration (UF) are low-pressure membrane processes that can be used to remove microorganisms and colloidal particles (Kennedy et al., 2008). MF/UF can be used as a pretreatment to RO. MF and UF membranes can be made from organic polymers or inorganic materials.

1.2.6 Reverse osmosis

Reverse osmosis is the most widely used membrane-based water treatment process. It is able to reject nearly all colloidal or dissolved matter. A pressure difference is applied across the membrane to force the permeate through the membrane. In order to overcome the feed side osmotic pressure, fairly high feed pressure is needed as depicted in Figure 1.1 (Fritzmann et al., 2007).

Figure 1.1. RO Schematic

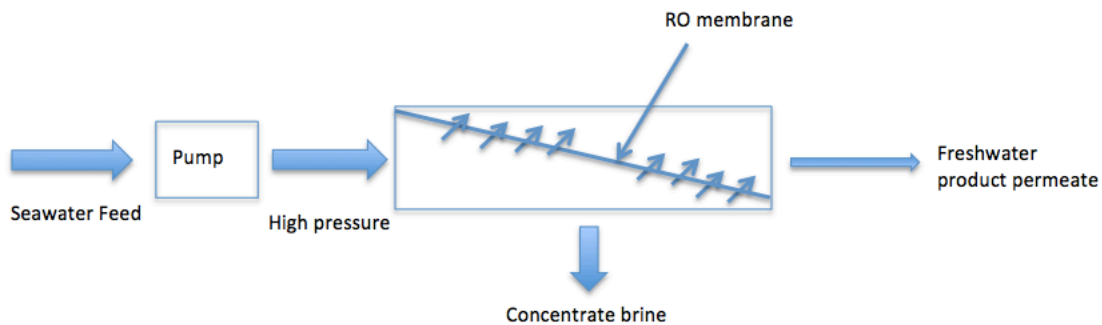

On the other hand, membrane processes do not incorporate phase changes. Membrane processes, in particular RO, continues to take market share from thermal desalination, with 59% of the total new build capacity being membrane based (Eltawil et al., 2009). The RO process requires energy inputs to overcome the natural osmotic phenomena between fresh-water and saltwater. RO relies on forcing salt water against membranes (cellulose acetate or aromatic polyamide) at high pressure, so that water

molecules can pass through membranes and the salts are left behind (Eltawil et al., 2009).

1.3 Desalination and renewables

Desalination systems driven by renewable energy sources are limited. They only represent 0.02% of total desalination capacity. (García-Rodríguez, 2002) Renewable energies provide various benefits to the environment and economy. Reducing carbon emissions, climate change mitigation, reducing air and ground pollution are some of the environmental benefits. Additionally, renewable energy can provide off-grid, self-sufficient supplies that are not susceptible to geopolitical volatilities and investment in diverse energy portfolios. In 2014 for the first time since 1974 the global economy grew but global carbon emissions stabilized (Foley et al., 2015). This is a stark contrast to previous decades where a decline in emissions was attributed to downturns in the global economy. The cause of emission stabilization has been attributed to the maturation of renewable energy and the advancement in energy efficiency (Foley et al., 2015). There has been a new wave of governments of both developed and developing countries considering and adopting renewable energy projects. For example, worldwide big players such as China, the European Union, Mexico, and the United States have declared their commitment to creating new climate change policies that would establish the underpinnings for future investment in renewables. Table 1.4 shows the abundance of PV-RO plants worldwide demonstrating that using photovoltaic systems is a mature and growing development.

Table 1.4. Reverse osmosis plants worldwide driven by photovoltaic cells; (García-Rodríguez, 2002)

Plant location	Salt concentration	Plant Capacity	Photovoltaic system
Jeddah, Saudi Arabia	42800 ppm	3.2 m ³ /d	8kW peak
Concepcion del Oro, Mexico	Brackish water	1.5 m ³ /d	2.5 kW peak
North of Jawa	Brackish water	12 m ³ /d	25.5 kW peak
Red Sea, Egypt	Brackish water (4.4 g/l)	50 m ³ /d	19.84 kW peak
Hassi-Kebi, Argelie	Brackish water (3.2 g/l)	0.95 m ³ /h	2.59 kWp
Cituis West, Jawa, Indonesia	Brackish water	1.5 m ³ /h	25 kWp
Perth, Australia	Brackish water	0.5-0.1 m ³ /h	1.2 kWp
Wanoo Roadhouse, Australia	Brackish water	—	6 kWp
Vancouver, Canada	Seawater	0.5-1 m ³ /d	4.8 kWp
Doha, Qatar	Seawater	5.7 m ³ /d	11.2 kWp
Thar desert, India	Brackish water	1m ³ /d	0.45 kWp
North west of Sicily, Italy	Seawater	—	9.8 +30 KW diesel generator
St. Lucie Inlet State Park, FL, USA	Seawater	2x0.3 m ³ /d	2.7 kWp + diesel generator
Lampedusa Island, Italy	Seawater	3+2 m ³ /h	100 kWp
University of Almeria, Spain	Brackish water	2.5 m ³ /h	23.5 kWp

1.4 Membrane Distillation

Membrane distillation (MD) is a thermally driven separation process that was introduced in the late 1960s but has not been widely developed. MD requires lower operating temperatures because it is not necessary to heat the process liquids above their boiling temperatures. Lower operating temperatures have made MD attractive in the food industry and in the medical field (Lawson & Lloyd, 1997). Additionally, lower process temperatures combined with reduced equipment surface area results in less heat lost to the environment through the equipment surfaces (Lawson & Lloyd, 1997). Since MD is a thermally driven process operating pressures are lower compared to RO processes. Lower operating pressure means lower equipment costs and increased process safety.

Various methods can be utilized to impose a vapor pressure difference across the membrane to drive flux. The four most common configurations of the MD process are: (i) direct contact membrane distillation (DCMD), (ii) air gap membrane distillation (AGMD), (iii) sweeping gas membrane distillation (SGMD), and (iv) vacuum membrane distillation (VMD) (Lawson & Lloyd, 1997). The two we are considering for our project are DCMD or AGMD.

- (i) Direct Contact Membrane Distillation (DCMD) involved a cooled permeate stream in direct contact with the opposite side of the membrane. The condensing medium for the vapor is the permeate liquid, which cannot pass through the pores (Saffarini, Summers, Arafat, & Lienhard V, 2012). This

configuration requires only external cooling of the permeate stream. As a result, this configuration is the most tested in laboratory bench-scale literature. The disadvantage of this system is the DCMD thermal inefficiency as heat is lost directly from the hot feed to the permeate by conduction through the membrane (Saffarini et al., 2012).

- (ii) Air Gap Membrane Distillation (AGMD) involves a gap of air on the permeate side of the membrane. The vapor passes through the pores condenses on a cooled surface maintained at a low temperature by a cooling fluid. Another advantage of AGMD over DCMD is that heat loss by conduction through the membrane is much more limited, due to the air gap. AGMD is the most used configuration in solar-powered membrane distillation (SP-MD) systems. However, one of the disadvantages of AGMD is the high mass transfer resistance due to the air gap, which limits permeate flux.

1.5 Comparing thermal technologies

Although RO is currently the state-of-the-art desalination technology, there are several challenges and opportunities. RO systems have a relatively low rate of energy consumption, but the high-cost of electricity. For both RO and MD the challenge lies in membrane fouling. Therefore, low-grade, waste and/or alternative energy sources such as solar and geothermal energy can be coupled with MD systems for a cost efficient, energy efficient liquid separation system. It has been stated that MD is a

safer, more efficient process than RO for removing ionic components and non-volatile organic compounds from water.

Membrane distillation (MD) is a hybrid of thermal and membrane processes. Membrane distillation (MD) is a thermal membrane separation process that is driven by phase change (Al-Obaidani et al., 2008). In membrane distillation, a hot, saline feed stream is carried over microporous hydrophobic membranes. The temperature difference between the two sides of the membrane led to a vapor pressure difference that causes water to evaporate and condense (Saffarini et al., 2012).

MD has promising applications worldwide. Specifically, the MD process can be used as a substitute for conventional desalination processes such as multi-stage flash (MSF), reverse osmosis (RO), and multiple effect distillation (MED). The advantages of MD to these existing technologies are: (i) lower operating temperatures and vapor spaces required than MSF and MED, (ii) lower operating pressure than RO (iii) 100% (theoretical) rejection of non-volatile solute, and (iv) performance not limited by high osmotic pressure or concentration polarization (Al-Obaidani et al., 2008).

MD has several limitations. The most significant limitation is that the process solutions must be aqueous and diluted to prevent wetting of the hydrophobic microporous membranes (Lawson & Lloyd, 1997). Thus, this prevents MD from being coupled with desalination and applied to removal of trace volatile organic compounds from waste water. Additionally, no capillary condensation can take place inside the pores of the membrane.

The advantages of membrane processes over thermal processes include: (Eltawil et al., 2009)

- lower capital cost and energy requirements;
- lower footprint and higher space/production ratio;
- higher recovery ratios;
- modularity allows for up- or downgrade and minimal interruption to operations when maintenance or membrane replacement is required;
- less vulnerable to corrosion and scaling due to ambient temperature operation; and
- membranes reject microbial contamination

Advantages of thermal processes over membrane processes include:

- very proven and established technology;
- higher quality product water produced;
- less rigid monitoring than for membrane process required;
- less impacted by quality changes in feed water; and
- no membrane replacement costs

1.6. Desalination and the environment

According to the World Health Organization (WHO), the allowable limit of salinity in water is 500 mg/L. The majority of the water available on earth has salinity up to 10,000 mg/L, and seawater normally has a range of 35,000-45,000 mg/L in the form of dissolved salts (Kalogirou, 2005). In order to purify brackish or seawater to the permissible limit of 500 mg/L or less, significant quantities of energy are needed. The high-energy demand is costly, excluding most countries that are water scarce. However, the Middle East has been a major leader in financing desalination due to their oil income. Desalination provides two advantages, namely, improvements in quality and sanitation and softening of the water (Einav et al., 2003). However, desalination also causes detrimental effects to the environment as described in the next section.

In 2000 the installed capacity was about 22 million m³/day, which is predicted to increase drastically. The projected increase of desalinated water supply is expected to create a series of problems, most pressing are those related to energy consumption and environmental pollution (Kalogirou, 2005). The installed capacity, mentioned previously, would require about 203 million tons of oil per year. Based on previous studies, the energy required to desalinate one m³ of water varies from due to feed water and technology. Generally, it is estimated that the amount of electricity required to produce one m³ of water ranges from 3.5-4.5 kWh/m³. The amount of crude oil estimated to produce one KWh is 234.9.

Water sources for desalination can originate from seawater and groundwater. The former desalination may have several negative aspects directly or indirectly on the environment. One of the notable indirect impacts on the environment is that desalination plants require an external supply of electrical energy. This external supply is typically produced by thermal plants, which need to burn fuel, and simultaneously emit polluted flue gases.

Marine life may also be affected by desalination as a result of returning the concentrated brine to the sea, which is usually 1.2-1.7 higher than the seawater's original concentration. Additionally, there is a negative impact on the marine environment as a result of the chemicals found in the cleaning of membranes and

pretreatment membranes. Noise pollution and the intense land requirement can all impact marine life (Sadhvani, Veza, & Santana, 2005).

In previous studies five themes have been associated with the impact of desalination on the environment ((Einav et al., 2003). 1) Adverse effect on land use; 2) Impact on the aquifer; 3) Impact on the marine environment as a result of returning concentrated brine to the sea; 4) Impact of noise; 5) Intensive use of energy.

1.7 Renewable Energy Policy

Recent studies show the advancement of clean energy technology: solar, hydro, and geothermal energy to produce water (International Energy Agency, 2014).

Opportunities arise stemming from the current shift toward higher-efficiency electricity generation and renewables; however technology deployment is a barrier to overcome. Renewable energy policies can inform and spur the adoption of photovoltaic and wind energy – which both require very little water. One of the barriers to adoption is that energy and water utilities are characterized by long investment cycles and are subject to many regulations, and are managed under stringent performance expectations (Energy, 2014). Consumer markets are largely driven by price and intangibles, and product lifecycles tend to be shorter.

Administrative processes often curb financiers and stakeholders willingness to undertake the risk of investing in new technologies (Energy, 2014).

The concerns for water-energy security are growing, as stressed by California's drought, the accident at Fukushima, and political unrest in Northern Africa. As a result, many governments from both developed and developing countries have made an effort to promote deployment of renewable energy. Renewables are the fastest growing sector of the energy mix (International Energy Agency, 2011). The problem is that rapid deployment of renewable energy is limited to only a small number of countries.

One of the roadblocks contributing to clean energy's deployment is the cost. Economic studies on renewable projects have shown that initial capital costs are higher than conventional fossil fuel generated projects. Other barriers are advancement in clean energy technology, storage, and smart grid. Despite current green growth frameworks and existing literature on coordinating policies current literature and previous studies do not provide options other than pricing instruments, regulations, and subsidies to address market and information failure. More efforts are needed to enhance policy coherence than merely discussing what is available and what has not worked. In both developing countries and developed countries it is not always the best technology that propels project developments; markets, incentives, and policy have proven to give project developers profit.

Another added challenge of the water-energy nexus is the growing need for more coherent approaches to inform relevant policies. According to the U.S. Department

of Energy, the decision making landscape is “complex” and “fragmented.” Given that the United States water and energy policies have been formulated independently poses an additional challenge. Nevertheless, the U.S. government is aware of the strong interconnections between water and energy systems and has chosen to update and align its energy policy initiatives such as the Quadrennial Energy Review and Climate Action Plan.

Previous renewable energy and climate change studies have presented strong evidences to support using a comprehensive suite of low carbon technologies to decrease carbon emissions, including renewables, nuclear energy, and energy efficiency. Furthermore, previous studies have concluded feed in tariffs (FITS) and tradable green certificates (TGC) schemes can have a significant impact on deployment levels, and be cost effective. This dissertation seeks to develop methods for deployment of potable water technologies for water scarce regions and to identify the development and deployment barriers and improve quantitative and technical understanding of coupling desalination with photovoltaics.

Under a business-as-usual scenario, the amount of global energy related CO₂ emissions could reach 62 gigatons (Gt) by 2050. To meet such a goal, significant steps, including reliance on alternative energy technology, must be taken to reduce carbon emissions to below 14 Gt. The World Economic Outlook, Energy technology Perspectives and International Energy Agency agree that three

schemes will aid in the energy demand that will increase from 1.6% to 2.5% First improved energy efficiency, increase deployment of renewables and the widespread introduction of carbon capture and storages. Improved energy efficiency: the largest share of the total emissions reduction (36%) will come from an increase in energy efficiency. The annual improvement in global energy intensity will increase from 1.6 to 2.5 %. This will require a doubling of energy efficiency. Increased deployment of renewable energy, the second largest share 21% of the reduction of emissions, is due to a massive further deployment of renewable energy technologies. By 2050, almost half of total electricity generation will be from renewable energy sources up from 18% today. Lastly, widespread introduction of carbon capture and storage (CCS) is needed which is the third largest share (19%) of emissions reduction. An average of 45 CCS coal-fired plants/year at 500MW and 25 CCS gas-fired plants/year at 1000MW would need to be built. Finally, continued fuel switching is another mechanism to diversify clean energy, which would necessitate an increase in the share of nuclear. This would require 32 nuclear plants/year at 1000MW.

In order to reduce the cost of desalination this study proposed the use of photovoltaics with reverse osmosis and not concentrating solar power (CSP). For desalination to work the temperature should be between 80C to 120C which is too low for CSP plants to operate. CSP has been designed to function at 300-500C. For future studies we will examine the possibilities of utilizing hybridized CSP

technologies for desalination that have been introduced in 2014 in Kuwait and Saudi Arabia and a CSP-geothermal plant in U.S.

1.8 Renewable sources to utilize

Renewable energy provides a method with a low environmental cost. Regions with a requirement for desalinated water can often be rich in fossil fuels but lack the ability the operational and logistical ability to make this a viable option. Renewable energy pilot facilities have had success for a few years now and can be set up to utilize specific energy locations such as tidal, solar, wind or geothermal. Despite the growing awareness of using renewables to ameliorate energy demands, there are inevitable hurdles with renewable energy adoption. The most obvious is the argument that fossil-fuel sourced energy provides a less expensive option in some cases, while renewables may have high capital costs with no long-term commitment (DLA PIPER, 2010).

Table 1.5. Comparison of renewable energy resources

Renewable energy source	Application	Advantages	Disadvantages
Solar	Solar still: Direct conversion of saline to potable water.	Simple process. Inexpensive material of	Energy loss in the form of latent heat of condensation

	<p>Solar pond: Utilization of salinity gradient to store heat and produce steam for electricity generation.</p> <p>Concentrated solar power: Hot fluid used in turbine generator for producing electricity.</p> <p>Photovoltaic cell: Conversion of sunlight directly into electricity to power RO desalination</p>	<p>construction can be utilized (Qiblawey and Banat, 2008).</p> <p>Beneficial use of desalination brine (Qiblawey, 2008).</p> <p>Same equipment used in conventional power plants can be used for concentrated solar power plants (DOE, 2010).</p> <p>Hybrid designs with other (wind) renewable energy sources are easily achievable. Well suited for desalination plants requiring electrical power (Eltawil et al., 2009).</p>	<p>(Mathioulakis et al., 2007). Large land area requirement (Kalagirou, 2005).</p> <p>Capital cost intensive. Output is intermittent (Trieb et al., 2009). Large land area requirement. Capital cost intensive. Output is intermittent (Kalagirou, 2005)</p>
Wind	Wind turbine: Wind energy used to generate electricity to power RO desalination.	Well suited for desalination plants requiring electrical power (Eltawil et al., 2009).	Output is intermittent. Resource is location dependant and unpredictable (Kalagirou, 2005). Resource is limited to certain locations (Kalagirou, 2005)
Geothermal	Geothermal steam to generate electricity to power RO desalination.	Continuous power output, predictable resource, thermal storage is not necessary	Output is intermittent. Resource is location dependant and unpredictable (Kalagirou, 2005). Resource is limited

		(Barbier, 2002; EGEC, 2010).	to certain locations (Kalagirou, 2005
--	--	------------------------------	---------------------------------------

Thermal solar is one of the most promising application of renewable energies to seawater desalination (García-Rodríguez, 2002). Similarly, solar photovoltaic energy can be used however the main problem is its high cost and energy efficiency between 13%-15% in mono-crystalline silicon cells. Wind power is a feasible alternative to solar since coastal areas have a high supply of wind speed. Biomass can be used to power a distillation process using thermo-mechanic conversion. However, biomass is not a promising solution since it is rare to find organic residues in arid regions. Ocean and tidal energy are not practical to power RO systems because wave energy is not yet commercial and tidal energy is expensive. Lastly, geothermal energy is a mature and competitive technology that has potential with more constant reliability than solar and wind.

1.8.1 Hybrid design for off-grid systems

Several studies on a suitable coupling of renewable energy sources with desalination processes propose that PV-RO and PV-ED technologies are a very promising among the existing options. (Bilton, Wiesman, Arif, Zubair, & Dubowsky, 2011), (Kalagirou, 2005), (García-Rodríguez, 2002), (Gude et al., 2010). The appropriateness of renewable energy technologies, wind turbines and photovoltaics, for RO desalination is highly suitable due to the fact that RO is capable for desalinating water for remote and isolated areas that are off-grid; it has low energy consumption and little need for maintenance (Mohamed & Papadakis, 2004).

Furthermore, studies have shown that PV/desalination systems are especially appropriate for remote regions that do not have access to the electric grid, and where solar radiation is high (K. Reiche, A. Covarrubias, 2000), (Al Suleimani & Nair, 2000), (Bilton et al., 2011), (Werner & Schafer, 2007), (Eltawil et al., 2009).

Deserts, rural areas, islands, and Mediterranean countries are finding renewables as a solution to their lack of fresh water. A hybrid (wind-PV) system was designed for (Mohamed & Papadakis, 2004) in Greece. This study provides an adequate case study for water shortage and the need for stand-alone systems. In this case it is a stand-alone hybrid wind-PV system to power a seawater reverse osmosis unit. Although this dissertation focuses on hybrid solar-PV systems it is important to understand renewable hybrid systems in general.

1.8.2 Photovoltaic systems

PV technology is a rapidly developing technology that is mature in its advancements and innovations, additionally the costs for PV installments have drastically declined with time (Al-Karaghoul, Renne, & Kazmerski, 2010). The benefits that PV achieves are low maintenance, low noise level, longevity, non-emission, and economic benefits. Two desalination methods that can be coupled with solar PV systems are RO and ED. PV modules convert solar radiation into direct-current (DC) electricity. Typical PV power systems consist of a charge controller, batteries, inverter, and other components.

1.9 PV-RO system economics

Cost figures for desalination have been difficult to obtain but as a general rule, a seawater RO unit has low capita cost and significant maintenance cost due to the high cost of the membrane replacement (Al-Karaghoulis et al., 2010). Additionally, the cost of the energy used to maintain the plant is also high. The highest energy parameter for RO desalination is for pressurizing the feed-water. With the aid of energy recovery, seawater reverse osmosis (SWRO) power consumption has been reduced to about 5 kWh/m³ for large plants and for small plants without energy recovery power consumption may exceed 15kWh/m³. Reports in the literature have shown that with PV the cost of desalinated water ranges from 7.98 to 29 US\$/m³ for a product water capacity of 120-12m³/day (Al-Karaghoulis et al., 2010). The high investment cost of renewable energy-based desalination plants may be reduced by appropriate investments to expand the renewable energy PV-RO desalination market.

1.9.1 Social and cultural barriers to technology adoption

This last section is a culmination of the subsequent sections on desalination and renewables. It is important to acknowledge that social aspects are as important, if not more, than technical, economic, and environmental aspects of small-scale desalination units powered by renewable energy for rural communities (Werner & Schafer, 2007).

Previously published literature has highlighted the importance of the human resources, operations, and management for remote countries and described the failure of technologies by way of abandoned and dysfunctional systems (Werner & Schafer, 2007). In the past there was a heavy reliance on deploying equipment and desalination units that worked in developed countries. This is highly problematic, as social aspects of desalination technologies should ideally be considered before a new technology is introduced. In order to be socially sustainable these technologies must be accepted by the community, meet their water needs, and be within their capacity to operate and maintain (Werner & Schafer, 2007).

1.9.2 Organization of the Dissertation

This dissertation investigates the economic and non-economic barriers and opportunities for small-scale and large-scale market penetration of renewable energy technologies in West Africa and Asia, a region currently wrought by the impacts of climate change (World Bank, 2012), (Biggs, Boruff, & Bruce, 2014). These regions were chosen because there is accelerating economic growth, growing population, high-energy demand, and increasing fossil fuel imports. However, these regions are also endowed with an abundance of renewable energy sources which only a few have been exploited while others have gone un-utilized.

The fundamental goal of this dissertation is to describe methods provide clean water using renewable energy for developing countries. To achieve this goal, this study included four major objectives. The first objective is to quantify the cost of water technology options in Ghana by evaluating the cost, environmental effects, social adaptability, and other factors. The second objective is to develop an economic model for solar desalination in order to examine the feasibility of a solar desalination plant in Southeast Asia. The third objective is to develop an off-grid solar water purification system to analyze the optimization of the system. Finally, the last objective is to review the challenges and barriers of water infrastructure policy in Asia and provides recommendations to ameliorate them.

The gap in the knowledge is forecasting the road to market deployment of renewable energy in developing countries. It has been seamless in some developed countries like Singapore, Germany, and Denmark. The contribution of this dissertation is to advance science, improve policy, and for government officials to make better.

This dissertation contains five chapters. Chapter 1 summarizes the problems and motivation of this dissertation work leading to develop the four major objectives. Chapter 2 provides an overview of the various water technologies accessible in Ghana and offers a selection method in order to decide which treatment technology or combination of treatment technologies is needed to treat surface water to safe drinking water levels. Chapter 3 models the cost analysis of a hypothetical solar desalination plant for Myanmar. Countries in Southeast Asia like Myanmar have a high annual average of 4.5-5.5 (kWh/m²/day), which is favorable for solar energy

use despite the challenges it faces such as electric grid connectivity and high water quality due to mining and agricultural activities. This chapter presents economic modelling and arrives at evidence that solar desalinated water cannot be sold at competitive price to the Myanmar market. Chapter 4 discusses the performance of a stand-alone water filtration system I created as a pilot system for rural villages in Southeast Asia, where approximately 7 out of 10 people are denied access to drinking water facilities. I developed a simple solar purification water system, which consists of a photovoltaic panel, a gravity-driven ceramic membrane filter, activated carbon, and ultraviolet light disinfection. This study's aim was to assess and evaluate the performance of the system in providing potable water from surface water. Chapter 5 analyzes strategies to close the financial gaps in Asia, while considering political challenges that may surface. This study conveys non-economic tools and resources local government leaders and consumers can feasibly utilize pertaining to water treatment system construction

References

1. U.S Department of Energy, (2014). The Water-Energy Nexus: Challenges and Opportunities. *U.S. Department of Energy*, (1), 1–262.
<http://doi.org/10.1007/s13398-014-0173-7.2>
2. Foley, T., Thornton, K., Hinrichs-rahlfes, R., Sawyer, S., Sander, M., Taylor, R., ... Hales, D. (2015). *Renewables 2015 global status report*.
3. DLA PIPER. (2010). Renewable energy in Asia Pacific. *A Reference Manual for Anyone Involved in the Energy Sector*, 1–92. Retrieved from <http://www.nortonrose.com/knowledge/publications/pdf/file29339.pdf?lang=en-gb>
4. Biggs, E., Boruff, B., & Bruce, E. (2014). *Environmental livelihood security in Southeast Asia and Oceania: a water-energy-food-livelihoods nexus approach for spatially assessing change. IWMI White ...* Retrieved from <http://eprints.soton.ac.uk/375451/>
5. MENA Development. (2012). *Renewable Energy Desalination An Emerging Solution to Close the Water Gap in the Middle East and North Africa*.
<http://doi.org/10.1596/978-0-8213-8838-9>
6. The World Bank. (2012). *Renewable Energy Desalination An Emerging Solution to Close the Water Gap in the Middle East and North Africa*.
<http://doi.org/10.1596/978-0-8213-8838-9>
7. International Energy Agency. (2011). Solutions for a low-carbon energy future. *Energy*.
8. IEA. (2009). Ensuring Green Growth in a Time of Economic Crisis : The Role of Energy Technology, 23.
9. International Energy Agency. (2014). Tracking Clean Energy Progress 2014 Tracking Clean Energy Progress, 84.
10. Schiffier, M. (2004). Perspectives and challenges for desalination in the 21 st century *. *Desalination*, 165, 1–9.
11. Sadhwani, J. J., Veza, J. M., & Santana, C. (2005). Case studies on environmental impact of seawater desalination. *Desalination*, 185(1-3), 1–8.
<http://doi.org/10.1016/j.desal.2005.02.072>
12. Charcosset, C. (2009). A review of membrane processes and renewable energies for desalination. *Desalination*, 245(1–3), 214–231.
<http://doi.org/10.1016/j.desal.2008.06.020>

13. Eltawil, M. A., Zhengming, Z., & Yuan, L. (2009). A review of renewable energy technologies integrated with desalination systems. *Renewable and Sustainable Energy Reviews*, 13(9), 2245–2262. <http://doi.org/10.1016/j.rser.2009.06.011>
14. Khawaji, A. D., Kutubkhanah, I. K., & Wie, J.-M. (2008). Advances in seawater desalination technologies. *Desalination*, 221(1–3), 47–69. <http://doi.org/10.1016/j.desal.2007.01.067>
15. Fewtrell, L., Kaufmann, R. B., Kay, D., Enanoria, W., Haller, L., & Colford Jr, J. M. (2005). Water, sanitation, and hygiene interventions to reduce diarrhea in less developed countries: a systematic review and meta-analysis. *The Lancet Infectious Diseases*, 5(1), 42–52. [http://doi.org/10.1016/S1473-3099\(04\)01253-8](http://doi.org/10.1016/S1473-3099(04)01253-8)
16. Lawson, K. W., & Lloyd, D. R. (1997). Membrane distillation. *Journal of Membrane Science*, 124(1), 1–25. [http://doi.org/10.1016/S0376-7388\(96\)00236-0](http://doi.org/10.1016/S0376-7388(96)00236-0)
17. Kalogirou, S. A. (2005). Seawater desalination using renewable energy sources. *Progress in Energy and Combustion Science*, 31(3), 242–281. <http://doi.org/10.1016/j.peccs.2005.03.001>
18. García-Rodríguez, L. (2002). Seawater desalination driven by renewable energies: A review. *Desalination*, 143(2), 103–113. [http://doi.org/10.1016/S0011-9164\(02\)00232-1](http://doi.org/10.1016/S0011-9164(02)00232-1)
19. Bilton, A. M., Wiesman, R., Arif, A. F. M., Zubair, S. M., & Dubowsky, S. (2011). On the feasibility of community-scale photovoltaic-powered reverse osmosis desalination systems for remote locations. *Renewable Energy*, 36(12), 3246–3256. <http://doi.org/10.1016/j.renene.2011.03.040>
20. Gude, V. G., Nirmalakhandan, N., & Deng, S. (2010). Renewable and sustainable approaches for desalination. *Renewable and Sustainable Energy Reviews*, 14(9), 2641–2654. <http://doi.org/10.1016/j.rser.2010.06.008>
21. Mohamed, E. S., & Papadakis, G. (2004). Design, simulation and economic analysis of a stand-alone reverse osmosis desalination unit powered by wind turbines and photovoltaics. *Desalination*, 164(1), 87–97. [http://doi.org/10.1016/S0011-9164\(04\)00159-6](http://doi.org/10.1016/S0011-9164(04)00159-6)
22. Montgomery, M. a, & Elimelech, M. (2007). Water and sanitation in developing countries: including health in the equation. *Environmental Science & Technology*, 41(1), 17–24. <http://doi.org/10.1021/es072435t>
23. United Nations, Millennium Development Goals Report, 2011

2. A Critical Review of Water Purification Technology Appropriate For Developing Countries: Northern Ghana as a Case Study

2.1 Introduction

We are in an era where water scarcity and water quality are of critical importance. Environmental managers, scientists, and government officials have already begun seeking solutions on how to manage water in the midst of global climate change and overpopulation. Although water makes up more than 71% of the Earth's surface, there is an ever-growing struggle to access clean drinking water. Despite fresh water being a renewable resource, the availability of potable water is limited in many regions of the world. Globally, 1.5 million people die each year due to water-related diseases in developing countries (WHO, 2000). Additionally, the 780 million people who do not have access to clean water represent more than 2.5 times population of the United States. African countries are among the many developing countries that are plagued by water quality issues, and only 37% have access to hygienic sanitation (WHO, 2000). Sub-Saharan Africa is a region of the world where the number of people without access to drinking water increased by 23% over the period 1990-2004 (WHO, 2000).

Out of all the countries in Sub-Saharan Africa, Ghana provides an outstanding case study for looking at water quality issues. The lack of clean drinking water and sanitation is a severe public health concern in Ghana, contributing to 70% of disease in the country (WHO, 2000). This is not, however, due to a scarcity of water resources. Ghana is endowed

with the Volta River system basin, which has 3.26×10^{13} gallons of water and an average flow rate of $1,210 \text{ m}^3/\text{s}$ ($42,730 \text{ ft}^3/\text{s}$). Also within the country is a southwestern river system in addition to underground water well supplies. Given the vast water supply available, the primary limiting factor for water consumption is the lack of a water treatment infrastructure.

Here, I discuss the barriers for rural Ghana to establish on-site drinking technology and evaluate develop different approaches that could be applied to a series for Ghanaian water supply situations. A general overview of Africa's water problem and the context of Ghana's water crisis will be discussed in detail. The challenges to the current state of rural Ghana's infrastructure are vetted and alternative solutions that will allow communities to access potable water are compared. Lastly, the economic feasibility and political barriers of creating on-site treatment for rural communities in Ghana are acknowledged and addressed. The findings are based on literature reviews of water treatment technology and a 30-day field observation throughout rural and urban areas in Ghana.

2.2 General Overview

The severe scarcity of clean water has both direct and indirect impacts on Africa's economic development. Direct impacts include waterborne diseases and low agricultural yields. Indirect impacts include impacts on economic activity. For instance, when individuals are frequently sick and spend significant caring for the sick, less time and energy are available for economic activity. The availability of safe and accessible water is a basic requirement for improving economic conditions in any given region. However, this phenomenon is especially acute in Ghana, which is located on the western coast of Africa,

bordering the Ivory Coast on the west and Togo on the east. Sub-Saharan Africa has among the highest rates of mortality associated with waterborne illnesses and sanitation. In the year 2000, Ghana had an estimated 10,000-20,000 deaths due to lack of clean water (WHO, 2002).

2.3 Ghana's water crisis: General context and overview

Ghana's population is estimated at 20 million people, with 58% living in rural areas and 42% in urban areas (WHO, 2004). The World Health Organization and Joint Monitoring Program (JMP) for Water Supply and Sanitation define urban areas in Ghana to be areas with populations of 5,000 or more. By contrast, areas with less than 5,000 people are deemed rural (WHO, 2004). More than half of the rural population in Ghana is susceptible to having contaminated drinking water and water-related diseases like guinea worm and diarrhea (WHO, 2004). In Ghana, the same water is typically used for washing, bathing, cooking, and cleaning. This means that there are numerous ways for pathogens to be introduced into drinking water supplies and subsequently cause infection.

Of overall disease in Ghana, diarrhea is the third most commonly reported and it is the most common waterborne infirmity. Diarrheal disease accounts for 25% of cases of infant mortality, which was estimated to be 110 per 1000 in the year 2000. (UNICEF, 2000) Waterborne illnesses also affect the life expectancy in Ghana. Currently life expectancy is approximately 56 years.

2.4 Water supply in rural areas of Ghana

In rural areas, the central government generally allocates fewer resources to the low population density areas, delaying development and causing a lack of critical infrastructure. Currently, 56% of the population in the rural areas of Ghana's northern region does not have access to clean drinking water and 92% do not have access to improved sanitation (WHO, 2000). The availability of potable water in rural areas of Ghana is estimated to be 63% (Joint Monitoring Programme, 2008). These regions tend to have lower population density and insufficient infrastructure.

Rural communities in Northern Ghana have attempted to utilize various types of infrastructure to obtain drinking water, including: surface water, hand dug wells, boreholes, spring, rainwater harvesting, and tanker trucks. In some cases, the safest option is to use groundwater. Ghanaians access groundwater through hand dug wells; however, groundwater is a questionable source because direct contamination from fecal matter in upper aquifers caused by septic tanks. Boreholes, (i.e. deep wells going down 40+ meters), are the only way to ensure clean ground water. However, boreholes require proper equipment and are prohibitively expensive for many of these communities.

2.5 Treatment Options

One of the greatest challenges to water quality in underdeveloped countries is the prevalence of microorganisms that causes disease such as *Cryptosporidium*,

Campylobacter, and rotaviruses. Even though bacteria are larger than viruses (about 0.5 to 3 μm) they can be difficult to remove by sedimentation (WHO, 1998). Protozoan parasites are the largest in size and can be removed efficiently by filtration if the effective pore size of the filter medium is small enough.

There are a variety of passive and active methods to improve microbial quality of water. These methods include plain sedimentation or settling, filtration, and chemical treatments options (WHO, 2013). In areas where clean well-water or potable supplies are not available, personal technologies can be used to provide water purified water for individuals or on-site treatment systems can be installed to serve small villages up to thousands of people.

2.6 Personal Treatment Options

Six commercially available drinking technologies for drinking water in Ghana for personal water purification are bottled water, ceramic clay pots (*kosim* filter), Lifestraw®, paper cloth filters, satchet bags, and solar water disinfection. A summary of each technology is provided below.

- *Bottled water*: Bottled water is a burgeoning method of providing clean water to communities in Ghana. The price of a 500 mL water bottle is approximately \$1 US.
- *Ceramic clay pots (kosim filter)*: Ceramic clay pots are highly effective at removing bacteria, viruses, and protozoa. Based on MIT research in Northern Ghana, *kosim* filters are known to remove 92% of turbidity, 9.4% of total coliforms, and 99.7%

of *E. coli* from unclean water sources (Swanton, 2007). Typically, ceramic filters hold 8-10 liters of water. Filters are produced locally at ceramic facilities and then impregnated with colloidal silver to ensure removal of bacteria in treated water. The price is about \$25 US for one ceramic clay pot, which are manufactured locally.

- *LifeStraw*®: Lifestraw® are developed by the European disease control firm Vestergaard Frandsen. This technology is a plastic tube that is 310 mm long and 30 mm in diameter, which can filter out 99% of bacteria and parasites. LifeStraw® utilize hollow fiber technology that efficiently filters water while it is pulled through the straw. Individuals can put the straw directly into a water source and sip clean water through the mouthpiece. The primary limitation of LifeStraw® is that it has the capacity to filter only 1600 liters, and once exhausted, will clog and not filter as efficiently. Nonetheless, a single straw can meet the needs of a family of five for up to two to three years (Vestergaard Frandsen, 2013). The antimicrobial efficacy of LifeStraw® was evaluated by the Department of Soil, Water and Environmental Science, University of Arizona, USA (2010). The Lifestraw® technology has met the US Environmental Protection Agency (USEPA, 1987) protocol for microbiological water purifiers testing, which requires a six log reduction of bacteria and three log reduction for protozoan parasites. The cost of each Lifestraw® is approximately \$24 US.
- *Paper/cloth filter*: Paper or cloth can be used as a filter to remove large particles from the water. Filtration improves the aesthetic quality of the water but has

unknown levels of the removal of pathogens. Standard filter papers of known efficiency are generally unavailable. Cloth filters can be made from silk, burlap, and cotton, and are essentially free because individuals use cloth that they typically own.

- *Sachet bags:* Sachet bags are plastic packaged drinking water bags of 500 mL. The water source for sachets is typically either a well or a on-site drinking water treatment plant. Sachets are sold throughout Ghana by local vendors (Stoler et al., 2012). The appeal of sachets is their small size, cheap price, as low as \$0.08 cents (US) per bag and easy availability. However, large amounts of litter from sachet bags can be observed strewn along the streets (personal observation, 2011). Additionally, a study by the University of Ghana found that out of 27 different brands of 500 mL sachet bags, 75% of the samples contained infective stages of pathogenic parasitic organisms (Kwakye-Nuako et al., 2007). Furthermore, the study indicated high levels of fecal matter, lead, manganese, and iron.
- *Solar Water Filtration:* Solar disinfection (SODIS) is a technique that was developed in the early 1980s. Transparent bottles are filled with contaminated water. Filled bottles are shaken to oxygenate and the bottle is exposed to the sun by being placed on a roof or rack for about six hours. Bottles will heat faster and to higher temperatures if they are placed on a sloped sun-facing corrugated metal roof. A disadvantage of SODIS is the relatively common use of old bottles. If used bottles have scratches, light transfer and overall effectiveness of SODIS. Additionally, bottle labels or their residue reduce the clarity of the plastic and disinfection efficiency of SODIS is reduced. Other major concerns with this method

are the leaching of plastic bottle material into the water and regrowth of bacteria previously formed in the water bottle. Thus, proper training in the use of SODIS is required for optimal efficacy.

- *Slow Sand filtration:* Slow sand filtration is a water filtration technology that cleans water as the water flows through the sand. Large microbes cannot pass through the sand pores and clean water filters through.

2.7 On-site Water treatment plants

A variety of technologies can provide on-site treatment, which vary in complexity and size. These solutions typically require capital investment; training and maintenance but have the greatest potential for long-term, sustainable potable water solutions. The aim of an on-site facility is to provide an affordable system that can be maintained by locals, who in many cases will have limited knowledge and ability. Currently, the Ghanaian government does not provide on-site treatment facilities for rural regions due to the high initial investment that is required. However, in the future, the government may be able to create an investment climate that would foster the installation of on-site treatment facilities in rural areas.

Ground-water wells: Northern Ghana has shallow ground water-wells, hand dug wells, boreholes, and piped systems. Groundwater quality is generally potable but can contain high concentrations of fluoride (Dapaah-Siakwan et al., 2006). In many areas, mining has

contaminated ground water. Locally dug and maintained wells are a potential longer-term solution but usually require planning and outside assistance.

2.8 Systematic Evaluation of Technologies

Criteria Used To Evaluate Technologies

To determine what water filtration technologies are currently available included the literature was reviewed and concepts from multi-criteria decision analysis (MCDA) were considered. MCDA is the general field of study that provides a framework for decision making in the presence of two or more conflicting objectives (Teclé and Duckstein, 1994). Furthermore, observations made during a 30-day field study supplement the findings. Personal and community water purification technologies were evaluated based on the following criteria: effectiveness (the likelihood of being used properly and successful in the community), capital cost, operating cost, energy consumption, environmental impacts, and waste generated. Effectiveness was based on the WHO standards for minimal health risks (smhr). Moreover, effectiveness was considered to be the most important of these criteria. The assessment developed in Table 2 should be of general use to individuals or organizations that consider a technology to an appropriate use for their circumstance. This methodology for ranking was judged suitable for the precision of the available data. However, a more sophisticated ranking methodology (Linkov et al., 2012) could be developed in cases where additional data are available.

Table 1
Assessment of personal and on-site water technologies

Treatment technologies	Capital Cost ^a	Operating cost (per liter) ^b	Effectiveness ^c	Energy Consumption ^d	Environmental Impacts ^e	Waste Generated ^f	Advantages	Disadvantages
Bottled water	\$0	\$1	High	Manufacturing, transportation	Low	Plastic bottles	Individual use	Temporary solution, possibly delaying long term solution, potential supply problem
Ceramic clay pot "kosim"	\$14	\$0	High	None	Low	Exhausted sorbents	Low cost, on-site alternative, potentially useful for families or groups.	Variable quality of locally-made filters, Viruses, no residual protection, recontamination, maintenance
Groundwater Well ^h	Highly variable and site specific	\$0	High	None after drilling	Low	None	Potential long-term solution	Maintenance and management required, easily contamination
LifeStraw [®]	\$0	0.015	High	None	Low	Litter	Contains no chemicals, portable	Limited to 1600 liters; one-person only; recurring cost; may delay long term solution
Cloth filter	\$5-10	\$0	Low	None	Low	None	Individual use or household level, affordable	Microbe removal varies by pore size
Slow sand filter	\$16-25	\$0	High	Pump, vents, and drain	Low	None	Simple to use, Small scale and community level.	Requires technical knowledge and training; Constant maintenance
Solar water disinfection (UV) (size)	\$0	\$1	Moderate, Function of sunlight, cloud cover	None	Low	Litter	Low cost, no energy required, on site	Leaching of bottle material, regrowth of bacteria, toxic chemicals still in the water; training
Water satchel	\$0	\$0.008	High	Manufacturing and transportation	Plastic waste, litter	Plastic bags	Individual use	Temporary solution, possibly delaying long term solution, potential supply problem
Water treatment plant	\$7,000-\$40,000	parts	High	Significant	Land required, potential pollution	Water treatment plant sludge	Long term water supply, May lead to economic growth, improved health	Requires capital investment, dedicated land, good quality source water, and competent management with training.

Table 2. Assessment of personal and on-site water technologies

^aCapital cost of \$0 is colored green, moderate range is yellow, high is orange, and significant expenses are coded red. These judgments were made based upon capital cost to per capita income of individuals in developing countries.

^bSame as above.

^cHigh effectiveness is colored green.

^dNo energy consumption is colored green. ^eLow environmental impacts are colored green. ^fNo waste is colored green.

^h30-50 feet.

The colors key indicates the level of acceptability for each parameter. Green is high acceptability, yellow is neutral, orange is moderate, and red is for low acceptability.

2.9 Criteria Ranking

1. *Cost*: Capital cost: Capital cost reflects the initial cost of the treatment technology.
2. Operating cost: The operating cost reflects the cost of operating and maintaining the technology.
3. *Effectiveness*: Effectiveness was measured according to standards set out by the World Health Organization (WHO). The ranking was based on standards set for minimal health-risk to the consumer, measured by levels acceptable for minimum health risks which are: 99.994% for *Cryptosporidium*, 99.99987% *Campylobacter*, and 99.99968% for rotavirus. Effectiveness was weighed significantly higher than the other parameters because avoidance of water-borne diseases is considered to be of paramount importance.
4. *Energy Consumption*: Energy consumption reflects the amount of energy that is needed to operate the technology per volume of water at maximum efficacy.
5. *Environmental Impacts*: The environmental impacts focuses on the impacts the water filtration technology has on factors including water quality, air quality, biota, and land.
6. *Waste generated*: Waste generated focuses on whether or not the technology produces a high level of waste, if the product can be recycled, and if the waste poses a public health risk.

2.9.1 Methodological Limitations

Cultural adaptability was examined but could not be ranked because there was not enough data available on the views of Northern Ghanaians on each water technology. Further studies should examine whether specific communities would be open to implementing new technologies.

Capital Cost & Operating Cost

For the capital cost and operating cost assessment, each technology was normalized to US dollars per liter. I assumed that a Lifestraw® could filter 1600 L based on the product information on the Lifestraw® website (Vestergaard, 2013). A water bottle costs less than a dollar. Therefore, it would take 1,600 water bottles to filter 1600 liters. The operating cost would be \$1,600 for 1600 liters.

- *Kosim* filters: The assumptions made were that it filter can pass through water at a rate of 3 L/hour. So at 9 L it would be \$5. Then calculations were adjusted to go from 9 L to 1600 L. The ceramic clay filter (*kosim*) costs approximately \$14 (US). The operating cost is ~\$885/1600 L.
- *Shallow groundwater wells*: The cost is highly variable and is dependent on the depth of the well and location.
- *Lifestraw*®: There is no capital cost. The operating cost is \$24/1600 L. (Vestergaard Frandsen, 2013)

- *Cloth filters:* The capital cost for cloth filters is the bucket and the cloth material. The operating costs takes into account how often the cloth needs to be replaced, which depends on how many liters of water are being passed through it.
- *Slow sand filter:* The capital cost for slow sand filtration is between \$16-\$25 (US) (low-moderate). The operating cost depends on how long the sand is clean and how clean the water is.
- *Solar water disinfection:* Operating cost is negligible if water bottles are reused.
- *Water satchet:* The capital cost for a satchet is about 8 cents per satchet or \$12.80 (US) per 1600L.
- *Water treatment plant:* The cost ranges from \$7,000-\$40,000 (US) depending on the sq. ft. of the facility and the location

Effectiveness

The range of effectiveness was measured based on the capability the technology had to filter 99% of bacteria, parasites, and or toxic chemicals. If it met the requirement the technology was given a high ranking if the technology did not meet this requirement it was given a low ranking.

Energy consumption

Energy consumption was evaluated by considered whether the technology had a high or low impact to the air, water, and land. If plastic waste was produced or there was a potential for contamination by multiple users than the technology was ranked as low energy consumption. However, a high ranking was given to technologies that had low or no environmental impacts

Waste generated

This parameter was evaluated base on the amount of waste material by each technology and was ranked from high to low. Of all the technologies, bottled water and Lifestraw® create the most waste in the form of litter.

2.9.2 Discussion

The findings show that the most advantageous short term solution to the water crisis in rural Ghana would be the utilization of a combination of personal options such as the Life Straw® and *kosim* pots (Table 1¹). However, long-term water security in rural Ghana will require government efforts and will depend upon the development of infrastructure such as a groundwater infrastructure, water treatment plants with distribution systems or on-site water filtration. Observational studies and local interactions have indicated that groundwater wells and *kosim* filters are more readily available and currently being adopted by small villages.

¹ The colors key in Table 1 indicates the level of acceptability for each parameter. Green is high acceptability, yellow is neutral, orange is moderate, and red is for low acceptability.

Ghana's water crisis needs a holistic approach because a variety of water filtration technologies are needed to confront the diverse and complex nature of Ghana's water dilemma. In choosing a holistic approach, each filtration technology would supplement each other's limitations. Alternatively, rural areas in Ghana should have access to a water treatment facility. LifeStraw® filters are particularly effective for villagers that need to travel throughout the day, allowing them to stop at a water source and drink clean water as needed. The disadvantage of focusing on personal options is that doing so may delay implementation of longer-term, more sustainable solutions. If drinking water can be obtained through vendors, even at high cost, the incentives for new treatment plants or wells are reduced.

The technologies that are not recommended for use in rural Ghana are water satchets, cloth-filters, solar filtration, and water bottles. These approaches do not meet adequate drinking water standards. Water satchets in particular generate excessive waste and have been shown not to meet WHO standards for clean water in studies.

Implementation of Solutions: The Role of the Government In Improving Human Welfare

In the face of surging populations without water and the economics involved with clean water supplies, Ghana's governmental agencies have the potential to play a significant role in making water easily accessible. However, the unwillingness of the government to

support water facilities effectiveness prevents for small rural communities and villages to have a way to mass-produce drinkable water. An infrastructure provision is necessary to improve the effectiveness of water quality. However, the government has not provided an initial investment for on-site water treatment facilities that would address basic water and sanitation needs. As a result, the private sector (small water systems), charitable organizations, and a small group of individuals, the Informal Service Providers (ISP), have stepped in but cannot provide area-wide supplies. Thus, Ghana's governmental agencies, that have greater financial resources, are not providing rural areas with infrastructure that would alleviate their drinking water problems.

Similarly, global organizations such as the United Nations have made goals to halve the population without sustainable access to safe drinking water and basic sanitation by 2015 (United Nations, 2008). Clean water issues were identified and addressed by the creation of the United Nations' Millennium Developmental Goals (MDG) in the year 2000. MDG is a series of eight international goals that serves to improve the quality of life in developing countries (MDG). Nevertheless, individual communities are still involved in combating the water problem. For example, rural water needs are being supplemented by boreholes and hand-dug wells with pumps made by locals. Sustainable long-term solutions will depend upon the development of supporting infrastructure that can maintain existing facilities, train operators, and provide growth as needed.

2.9.3 Conclusion

This study analyzes the known alternatives for rural Ghana and proposes that, for long term solutions, the government and other agencies should focus on creating on-site water treatment facilities. While there is barriers to this long-term solution, such as cost, politics, and cultural adaptability, its emphasis on location-based treatment have the benefit of providing high quantity clean water to the community. For Ghana to reap the economic and social benefits of a nation with access to clean, potable water, the country's leaders must focus on creating water infrastructure for rural regions. Future work should focus on reducing the level of waste generated from personal water treatment.

References

1. Agyeman K. 2007. Privatization of water in Ghana: stopped in its tracks or a strategic pause? *International Journal of Environ Studies*. 64 (5) 525-536.
2. Dapaah-Siakwan S. & Gyan-Boakyee P. 2000. Hydrogeologic framework and borehole yields in Ghana. *Hydrogeology Journal*. 8 (4) 405-416.
3. Joint Monitoring Programme. Progress on drinking water and sanitation: special focus on sanitation. 2008. WHO, Geneva and UNICEF, New York, World Health Organization and United Nations Children's Fund Joint Monitoring Programme for Water Supply and Sanitation (JMP).
4. Kwakye-Nuako G, Borketey P.B., Mensah-Attipoe I, Asmah R.H., & Ayeh-Kumi P.F. 2007. Satchet Drinking Water In Accra: The Potential Threats Of Transmission Of Enteric Pathogenic Protozoan Organisms. *Ghana Medical Journal*. 41 (2) 62-67.
5. Linkov, I. & Moberg, E. Multi-criteria Decision Analysis: Environmental Applications and Case Studies. Boca Raton, FL: CRC, 2012.
6. Nyarko KB, Odai SN, Wusi PA, and Quartey EK. 2008. Water supply coping strategies in Accra. *33rd WEDC International Conference*. Access to Sanitation and Safe Water: Global Partnership and Local Actions, 417-420.
7. Swanton, Andrew. 2007. Evaluation of the Complementary Use of Ceramic (*Kosim*) Filter and Aquatabs in Northern Region, Ghana. Tufts University.
8. Stoler J, Weeks, J.R, & Fink G. 2012. Satchet drinking water in Ghana's Accra-Tema metropolitan area: past, present, and future. *Journal of Water, Sanitation, and Hygiene for Development*. 224: 223-240.
9. Tecele A. & Duckstein L. 1994. Concepts of multicriterion decision-making. In: Bogardi JJ and Nachtnebel HP (eds.) *Multicriteria Analysis in Water Resources Management*. UNESCO. Paris: 33-62.
10. Vestergaard Frandsen. Life Straw Features. available at: <http://www.vestergaard-frandsen.com/lifestrw/lifestrw/features>. (accessed April 17, 2013)
11. WHO. 2004 Guidelines for Drinking Water Quality. 2ne ed. Vol. 3. *Surveillance and control of community supplies*. Geneva, World Health Organization. available at http://www.who.int/water_sanitation_health/dwq/guidelines4/en/. (accessed March 2, 2013)
12. WHO/UNICEF Joint Monitoring Programme for Water Supply and Sanitation (2000) *Global water supply and sanitation assessment 2000 report*. Geneva, World Health Organization, Water Supply and Sanitation Collaborative Council and United Nations Children Fund.

13. WHO. "Managing Water in the Home: Accelerated Health Gains from Improved Water Supply." available at http://www.who.int/water_sanitation_health/dwq/wsh0207/en/. (accessed 10 May 2013)

3. Technical and economic evaluation of an off-grid solar desalination system in Myanmar

3.1 Introduction

Lack of sufficient and clean water affects about 700 million people worldwide. Population growth, droughts, and increased water contamination have led to global water scarcity. By 2025, nearly two-thirds of the global population will be affected by water issues [1].

The Republic of the Union of Myanmar, previously known as Burma, is the second largest country in Southeast Asia with a population of more than approximately 60 million, with more than 70% living in rural areas. Myanmar is situated in Southeast Asia and is bordered on the north and north-east by China, on the east and south-east by Laos and Thailand, on the south by the Andaman Sea and the Bay of Bengal and on the west by Bangladesh and India. It ranks as one of the least developed countries by United Nations criteria [5]. Myanmar has an estimated poverty level at 26 percent. The poverty level is twice as high in rural areas where 70 percent of the population resides. Myanmar is endowed with water supply and has 2234 km of uninterrupted coastline along the Bay of Bengal and the Andaman Sea [6]. Its monsoon seasons provide an abundant source of water; however, water scarcity still challenges the country. For example, the Ayeryarwady and Tanintharyi regions are susceptible to monsoons and flooding.

Although Myanmar has access to ten river basins, the increase in population and growing need for water for economic purposes has placed pressure on surface water and groundwater extraction. Myanmar relies heavily on hydropower for most of its electricity

generation. The electricity sector fails to meet the country's needs, with about 49% of the total population and only 29% of the rural population having access to electricity in 2011, according to IEA estimates [20][4]. Furthermore, outdated power plants and poor electricity transmission infrastructure cause severe power shortages. Consequently, natural resources (wood, charcoal, manure, and crop residues) are widely utilized and account for about two-thirds of the country's primary energy consumption [21].

3.2 Overview of Desalination

Desalination is a viable solution for the coastal areas of Myanmar because of the abundant supply of brackish and sea water and the ability to dispose of brine in coastal waters. As a result, over the past decade, desalination has become increasingly popular in many water-stressed areas [3]. However, oceans and brackish groundwater have salinity levels greater than 30,000 mg/L total dissolved solids (TDS) and World Health Organization's standards for drinking water require less than 1,000 mg/L [2].

Desalination techniques include multi-stage flash (MSF), multiple effect evaporation (ME), vapor compression (VC), reverse osmosis (RO), ion exchange, electrodialysis (ED), phase exchange, and solvent extraction. In the early stages of their development, desalination plants relied primarily on thermal energy, which heats seawater and then condenses the vapor to produce fresh water. However, advances in membrane technology have made RO the preferred choice for desalination operations, because it is less energy-intensive than thermal desalination [7]. Thermal processes such as ME, VC, and ED have not been considered for this paper. Thus, the focus of this paper is on RO desalination

plants that derive part of their electric energy from photovoltaic (PV) cells. Besides wind, solar-powered desalination is the most common renewable energy conversion method used to produce potable water. For a sustainable water supply, solar power provides a solution that does not add carbon emissions and is getting increasingly economically viable.

Desalination coupled with solar energy reduces the dependence on fossil fuels considerably. Thus, it is a promising solution for supplying fresh water to remote arid areas with high solar irradiance and low electrical grid connectivity. The lack of stable electricity has left over two-thirds of the country with intermittent power outages and without access to electricity [4].

Solar energy is a clean, cost-efficient, and renewable source of energy. Additionally, solar energy provides various benefits to the environment and economy such as reducing carbon emissions, climate change mitigation, reducing air and ground pollution. Despite solar-assisted desalination having its environmental challenges, it may serve to mitigate carbon dioxide emissions, while providing clean water to rural villages. Additional sources of water are needed and a common way of providing additional water supplies is through ultra filtration or reverse osmosis such as desalination. However, desalination is usually the last option for water purification since it requires a large amount of energy with an estimated range from \$1.57 to \$3.55 per m³, this varies by the type of feedwater, type of energy used, and daily capacity [8].

The cost of solar panels has declined substantially over the past five years and energy can be stored for use during cloudy days. Thus, it is a promising solution for supplying fresh water to remote areas with high solar irradiance. This paper analyses the feasibility of solar desalination for Myanmar's Ayeryarwady and Tanintharyi regions. An economic and technical analysis is provided using parameters suitable for Myanmar.

3.3 Modelling Assumptions

Several sources for social, economic, and governmental data were used to build the economic model and identify the key parameters for the hypothetical desalination plant. Numerous data sources were utilized for this study, including textbooks, databases, governmental sources, and country-specific websites. Various desalination reports were used to develop a solar desalination plant for the Ayeryarwady and Tanintharyi regions using existing costs for desalination equipment, solar energy systems, and storage solutions available on the market. Although the proposed plant is based in Myanmar, variable ranges of capital and operational costs were considered to broaden the model's applicability.

Key parameters of the model are:

- *Salinity*. A lower feed salinity allows for higher conversion rates and increased production. For the case study, the salinity for seawater in Myanmar was assumed to be 35,000 mg/L.
- *Product*: The permeate (effluent) is expected to be within the standards of the World Health Organization (WHO).

- *Plant capacity.* The plant will operate at a capacity factor of 0.85; it will thus produce 16,000 liters per day.
- *Energy requirement.* The desalination equipment consumes approximately 143 kWh/day, while auxiliary consumption is estimated to be 5 kWh/day. Hence, the daily consumption is approximately 148 kWh/day or 54 MWh per year.
- *Storage:* The system is designed to be off-grid, with storage three days product water storage.
- Water is distributed using mobile units such as tanker trucks and containers that people in remote communities manually transport, so there are no costs for pipes or distribution infrastructure to be taken into consideration.
- The power storage system used is designed to cover three days of autonomy, which is defined as the number of days the system can operate when there is no power from the photovoltaic panels. Lead acid batteries would be used as they are considered more durable over the twenty year plant life.

3.4 System design

Figure 3 shows an overview of the desalination plant operation. The proposed system consists of desalination equipment powered by solar panels and has sufficient battery storage to ensure that the system can operate with three days during cloud cover or other adverse weather conditions.

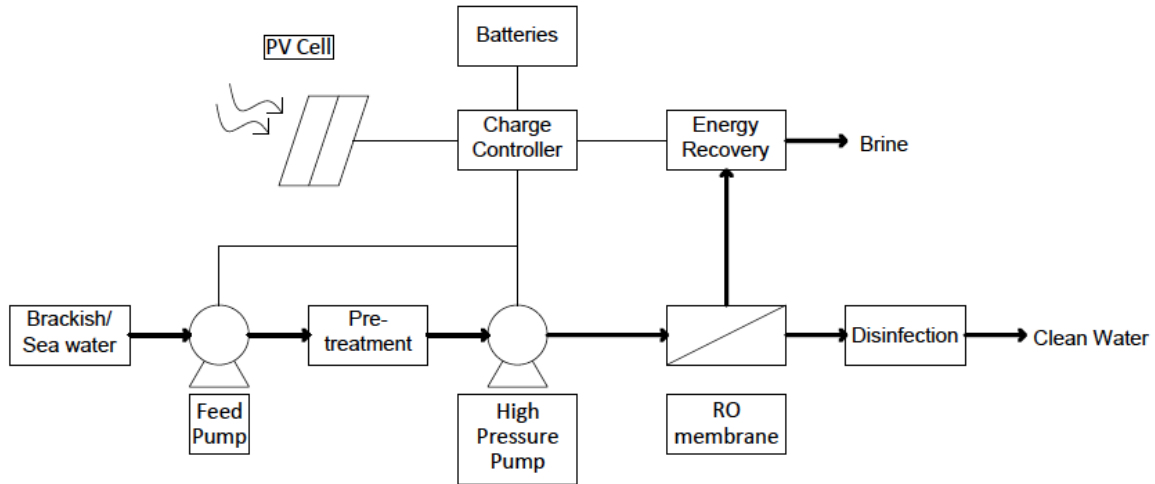

Figure 3. Solar desalination flow diagram

The solar panels proposed for the system are mono-crystalline modules, which will be primarily mounted on the rooftop of the main building containing the desalination equipment, with the rest on the ground. The inverters and batteries were in the main building as well. Deep cycle flooded lead acid batteries cells with a capacity of 820Ah and 6V will be used while the system voltage is 24V.

3.5 Capital expenditure

Table 3.1. Capital costs of system

Capital Expenditure			
Category	Item	Parameterization	Cost
RO System	Construction costs	Function of plant size and cost of land	\$76,000.00
	Pretreatment	Function of pretreatment disinfection and membrane filtration	\$10,000.00

	Intake	Estimated at 5-20% construction costs	\$16,000.00
	Discharge	Estimated at 5-15% construction costs	\$8,000.00
	RO System Equipment	Function of membrane filtration, pumps, steel welded pipe, pumping station building, and storage tank	\$80,000.00
PV with storage	Installation costs	Function of cost of solar system components per kW _p \$US 173,000.	\$327,000.00
Total			\$517,000.00

3.5.1 Construction and permits

The proposed solar desalination system requires an area of approximately 440m². This will include one main building which houses the desalination equipment, inverters, batteries and a computer for data transfer or communication. The building is estimated to have a built area of 220 m² and the remaining area will make up installed solar panels. The cost of land is estimated to be in a range of \$10-13/m² [21]. It was assumed that the average building construction cost for the structure only was \$321 sqm [18].

3.5.2 Distribution

The distribution system consists of an interconnected series of pipes, storage facilities, and components that convey desalinated water to the end user. However, for Ayeryarwady and Tanintharyi regions we assume that water will be distributed through mobile units such as tanker trucks and containers that people in those communities manually transport. Due to the undeveloped infrastructure, we excluded piping to avoid a distribution network that

would need routine maintenance. The costs for distribution and infrastructure were excluded. If the desalination system is farther away from the coast, costs for trucks, carts, animals, and maintenance, and containers could be estimated [10].

3.5.3 RO system equipment

Ampac USA is a seawater desalination manufacturing company that systems provide a full functional reverse osmosis treatment. A compact seawater desalination unit was the basis for the calculations. The system includes a feed pump, high pressure pump, safety stainless steel relief valve, high rejection RO membranes, dual stage micron filtration, product diversion valve, remineralizing filter. Maximum production is rated at 19,000 liters per day with a power requirement of 460V. The model is based on the price of Ampac Unit SW5000-BX with a retail price of US\$29,000-\$34,000 [11].

3.5.4 Photovoltaic installation and storage

The hypothetical desalination system would be in a remote location and hence completely solar powered, with storage available for operation at night and times of reduced irradiance. As the equipment is expected to effectively run 24 hours a day for the entire year (apart from maintenance), the different items of equipment that use electricity were identified and total consumption for the year was estimated.

The solar desalination equipment requires 7kW power while other auxiliary equipment like computers and lights consume approximately 5.4kW. Using these numbers, the total energy requirement of the desalination system was approximately 62.8 MWh per year. The annual solar irradiation of Yangon was found to be 1,665 W/m²/year and this was used as

the base to estimate the amount of energy a well-designed PV system can generate. Considering that the solar panels undergo a mean annual degradation of 0.8% [12], the system was increased in capacity by 30% to compensate for this degradation. Hence, the system size was found to be 61.41 kWp. Assuming 260Wp polycrystalline panels to be used in the project, the total required area was calculated to be 461 m². The cost for installation of solar PV systems in Myanmar was found to \$3.00/Wp and hence the total system cost was calculated to be \$184,220.

The storage system used for the solar desalination system is expected to have three days of autonomy which is defined as the number of days needed for the system to operate when there is no power produced by PV panels. The technology for the batteries used would be lead acid as they are considered to be more durable over the course of twenty years which is the time period assumed in the financial calculations. The battery that was selected for this purpose was Rolls Surette Battery 8 Volt 820 AH 6-CS-25PS [13]. The battery bank capacity that was calculated based on the total energy required and the days of autonomy was found to be 172.8 kWh which would lead to 26 batteries used on site for the system. Based on the costs of individual batteries the total capital expenditure for storage was found to be \$38,259.

3.6 Operating expenditures (OpEx)

Table 3.2 lists the annual operational expenditures for the desalination plant. These values are a result of our proposed model.

- Assuming that one operator for two shift per day is required and they are paid at three times the minimum wage of \$US2.80/day [8] , the labour cost for the plant was will \$US500/month, excluding benefits and other allowances.

Table 3.2. Annual operational costs of system (in USD)

Operational Expenditure			
Category	Items	Parameterization	Cost (pa)
RO System	Maintenance (Pre, Equip, Post, Bldg, Electrical)	15% of capital cost	\$15,000
	Labor	Function of wages cost	\$9,000
	Membrane Replacement	Function of membrane replacement cost and plant capacity	\$6,000
	Residuals Management	Function of plant capacity and water salinity	\$7,000
PV with Storage	Operation and Maintenance of PV system	Includes cleaning and corrective maintenance	\$1,000
	Operation and Maintenance of batteries	10% of capital cost	\$17,400
Total			\$55,400

3.6.1 Pre-treatment and membrane replacement

Membrane degradation is a natural process that occurs over 2-5 years, incurring additional costs for membrane replacement. The rate of degradation increases if the feed-water is not pre-treated for de-chlorination. Assuming a year-round operation would

produce 7,300 MG, or 28,000,000 m³ of water per year. The cost of membrane replacement is about \$1,100 and assumed to be replaced every three years [14].

3.6.2 Brine disposal

Residuals management costs are largely affected by the type of effluent produced post-desalination affects the residuals management costs and the steps needed to treat and dispose of it [3]. According to the World Health Organization (WHO), 90% of such projects dispose of the effluent directly into the ocean via outfalls [15]. The most direct complication results from possible shoreline impacts, such as high salt concentration in the marine ecosystems. However, ensuring full marine safety leads to increased disposal costs typically exceeding 30% of total desalination plant expenditures [16]. Using existing diffusers, such as power plant discharges, can reduce brine disposal costs. In this model, disposal costs were a function of discharge location and salinity concentration.

3.6.3 Photovoltaics and storage costs

PV systems are considered to have very low maintenance costs due to the lower number of moving parts. Hence, the total Operation and Maintenance cost was estimated as a factor of the total capital cost. As the system will be in a comparatively less accessed region, this could increase the O&M costs. Hence, as a conservative estimate \$18/kWp was used for the financial analysis. The operation and maintenance costs related to the storage was considered to be minimal however it was assumed that the batteries will be replaced every 5 years.

3.6.4 Labor costs

The specific cost of individual operation and maintenance positions to run a RO plant falls outside the scope of this solar-assisted desalination model. Assuming a minimum number of required personnel, the estimated labour cost for the model plant was based on two operators working at \$400/month and six supporting staff at \$100/month [9,17]. These estimates exclude benefits and other allowances.

3.7 Discussion

The financial analysis was done assuming a situation of 100 % equity as the cost of capital could be very specific to an entity in order to calculate the Internal Rate of Return. The parameter used to measure the profitability of the project was chosen to be IRR and from the financial analysis it was found that the project will have an IRR range of 11.9%-16.8% if the water produced is sold at \$0.015/liter-0.03 liter [18] which is a fraction of the current price of between \$0.12 - \$0.22 [19]. The financial analysis included a sensitivity analysis based on the parameters which were considered to be crucial in the calculations. As can be seen, the financial viability is most sensitive to the changes in selling prices of water, followed by the changes to the PV system cost. It was determined that the minimum hurdle rate for this project would need to be 13-15% due to political and currency risk. In order for the IRR to be less than the hurdle rate, the price of solar desalinated water should be

sold at 2.24¢/liter. This is relatively cheap compared to the current price of water 12-22¢/liter (23).

While this model serves to detail the basic framework of desalination operation and production, many economic, construction, environmental, and planning factors remain uncertain. As rural villages in Myanmar rely heavily on agriculture and mining for their income, demand for fresh water is expected to increase, further hampering traditional sources. Additionally, the demand for solar desalination could potentially create a market for PV panels. Ultimately, this market could create jobs and increase Myanmar's economic activity and performance, while decreasing dependence on using natural resources for energy consumption. As of 2014, Myanmar has a grid emission factor of 0.7134 (tCO₂/MWh) [22]. It was calculated that the carbon dioxide reduced with a solar desalination plant would be about 44 tCO₂.

A fundamental question lies in how will the people of Myanmar afford a financially viable solar desalination plant. In order for the plant to be afforded, a collaborative effort would need to be made with the government, international aid organizations, grants, and donors. A foreseen challenge is the high interest rate the project loan may be given due to political and currency stability in Myanmar. However, the World Bank or Asian Development Bank (ADB) may be able to reduce the risky investment cost. Despite the growing awareness of using renewables to ameliorate energy demands, there are inevitable hurdles with renewable energy adoption. The most obvious is the argument that fossil-fuel sourced

energy provides a cheaper option in some cases, while renewables may have high start up costs with no long-term commitment

3.8 Conclusion

This model details the economic issues of desalination, many economic, construction, environmental, and planning factors remain uncertain. Water availability strongly correlates to food production and industrial output. As rural villages in Myanmar rely heavily on agriculture and mining for their income, the demand for fresh water increases, placing further constraint on traditional sources. Myanmar has a lack of basic infrastructure and limited access to social services. The characteristics and constraints for this model were to manufacture a prototype that could run under intermittent power, located in a region with high solar irradiance, close village density, and high precipitation. From the analysis, it was concluded that the price of water should be approximately 2.24¢/liter in order to ensure that the project is profitable. However, it is important to understand that the cost of water can be further reduced with the reduction in cost of PV system and storage, which would ensure that clean water is available at affordable price to the rural villages of Myanmar.

References

1. Water Scarcity, United Nations Department of Economic and Social Affairs (2014), <http://www.un.org/waterforlifedecade/scarcity.shtml>
2. World Health Organization, Guidelines for Drinking-Water Quality, Fourth Edition, World Health Organization (2011) 1-564.
3. Q. Schiermeier, Water: Purification with a Pinch of Salt, *Nature* 452 (2008) 260-261. http://www.yale.edu/env/elimelech/News_Page/Nature_Special_Report.pdf
4. World Economic Forum (2013), New Energy Architecture: Myanmar http://www3.weforum.org/docs/WEF_EN_NewEnergyArchitecture_Myanmar_2013.pdf
5. Hiroshi Sakai: Quality of Source Water and Drinking Water in Urban Areas of Myanmar, *Scientific World Journal*. 2013; 2013: 854261.
6. Water Environment Partnership in Asia (2014), State of Water Environmental Issues: Myanmar. <http://www.wepa-db.net/policies/state/myanmar/myanmar.htm>
7. H.M. Ettouney, et al., Evaluating the Economics of Desalination, *CEP Magazine* (2002) 32-39.
8. Karagiannis, I. C., & Soldatos, P. G. (2008). Water desalination cost literature: review and assessment. *Desalination*, 223(1-3), 448–456.
9. Reuters, 2015. “Myanmar sets \$2.80 daily minimum wage in bid to boost investment. <http://www.reuters.com/article/us-myanmar-economy-wages-idUSKCN0QY0A620150829#cb8T5MmXq1s0ebAv.97>
10. P. Jagals, L. Rietveld, Estimating Costs of Small Scale Water Supply Interventions (2011) http://www.who.int/water_sanitation_health/economic/chapter7.pdf

11. Ampac USA Seawater Desalination Watermaker Land-based (SW5000-LX)
<http://www.ampac1.com/products/sea-water-desalination/sw5000-lx.html>
12. Dirk C. Jordan and Sarah R. Kurtz; Photovoltaic Degradation Rates - An Analytical Review (2012) <http://www.nrel.gov/docs/fy12osti/51664.pdf>
13. Rolls Flooded Deep Cycle Battery (2014)
<http://rollsbattery.com/public/specsheets/6CS25P.pdf>
14. M. Elimelech, W.A. Phillip, The Future of Seawater Desalination: Energy, Technology, and the Environment, Science 333 (2011) 712-717.
15. Stand-alone Ocean Discharge Technologies, Water Research Foundation, University of Santa Cruz Center for Integrated Water Research (2010),
https://ciwr.soe.ucsc.edu/sites/default/files/CCM_B2.pdf
16. Guidelines for Implementing Seawater and Brackish Water Desalination Facilities, Water Research Foundation and Arsenic Water Technology Partnership (2010) 257.
17. Country Report Myanmar (2013).
<http://www.bca.gov.sg/ExportServices/others/MyanmarCountryReport.pdf>
18. Invest Myanmar (2013): Cost of Utilities in Myanmar
http://www.investmyanmar.biz/re_pdfs/1363243651_pdf_Cost%20of%20Utilities.pdf
19. Communities Produce Drinking Water: German Technology contributes to affordable water supply in Myanmar (2014)
http://moerkwater.com/wp-content/uploads/PPP-factsheet_Myanmar-GIZ_M%C3%B6rk1.pdf

20. Location, location, location: Myanmar's the hot new neighbourhood. Reuters (2014).
<http://www.reuters.com/article/2012/01/30/uk-myanmar-property-idUSLNE80T00Y20120130>

21. U.S. Energy Information Administration. Burma Overview. (2014).
<http://www.eia.gov/countries/country-data.cfm?fips=bm>

22. Grid Emission Factors Myanmar.
<http://pub.iges.or.jp/modules/envirolib/view.php?docid=2136> (2014)

23. Johannes Puy, Mörk Water Solutions. "Communities produce drinking water: German technology contributes to affordable water supply in Myanmar."
http://moerkwater.com/wp-content/uploads/PPP-factsheet_Myanmar-GIZ_M%C3%B6rk1.pdf

4. Policy strategies and approaches for financing photovoltaic-powered water purification and desalination units

4.1 Introduction

By 2025 it is estimated that approximately 3.5 billion people, almost half of the world's population, will have inadequate water supply [1]. Additionally, it is projected that 2 billion people, one third of the global population, will not be connected to an electrical grid [2]. The Food and Agriculture Organization (FAO) of the United Nations predicts by 2025 that 120 countries will experience water stress or water scarcity [3]. Regions that fall into this list include Southeast Asia, North Africa, the Middle East, the Mediterranean, the West Indies, and Central Asia [3,4]. The top water-stressed countries predicted in 2040 are Bahrain, Kuwait, Qatar, San Marino, Singapore, United Arab Emirates, Palestine, Israel, Saudi Arabia, and Oman.

One of the United Nations' Millennium Development Goals targets was to reduce by half the proportion of people without access to safe drinking water by 2015. This international target was met five years before the deadline. According to the World Health Organization (WHO) and Unicef joint monitoring program (JMP), from 1990 and 2010 over 2 billion people acquired piped supplies and protected wells. However, the JMP warned that the data collected only analyzed access to improved water sources and did not assess the quality, or reliability of the water supply, or whether the water sources were sustainable.

Despite significant progress in water, much remains to be done. Meeting the needs for clean water and clean energy is an opportunity for novel clean energy technologies that

can address the water and electricity sector. This paper investigates the challenges and opportunities of implementing solar water disinfection systems using photovoltaics and UV radiation in urban cities and rural areas. The main focus of this article is to evaluate the social, economic, and political feasibilities of providing solar-powered technologies in various countries. Singapore, Oman, Ghana, and Chile were assessed. Additionally, a scaled-down prototype experiment for Southeast Asia is presented in more detail. The findings of this research can serve as a basis for private investors interested in entering the photovoltaic, desalination market.

Methodology for selecting water-stressed regions

To decide on countries to analyze, we used climate model and socioeconomic scenarios from the World Resources Institute (WRI) database. We defined water stress as the ratio between total water withdrawals and available renewable water at a sub-catchment level. WRI uses a scale from 0 to 5 that correspond to greater competition among water users relative to available surface water resources [11]. The WRI scored and ranked future water stress regions and projected 33 countries that will face significant water stress by 2040 [12]. Of the 33 likely most water stressed countries seven countries are categorized extremely stressed with a score of 5.0 out of 5.0: Bahrain, Kuwait, Qatar, San Marino, Singapore, United Arab Emirates, and Palestine [12]. To ensure a broad representation of water-stressed regions we chose countries from different continents that rank high for water-stress. Four water-stressed countries were chosen, Singapore, which ranked 5.0/5.0, Oman, which ranked 4.97/5.0, Chile, which ranked 4.45/5.0, and lastly, Ghana with no WRI ranking.

Singapore is a model for water technology, specifically water reuse and desalination. With inadequate access of water from rivers and dependence on Malaysia's water, this resource-starved island-state has become an international leader in water technology. Next, Oman was chosen because it has potential for adopting solar desalination. Renewable energy does not exist in the country's energy supply despite excellent potential for large-scale solar exploitation. Thus, there is potential in implementing pilot solar desalination plants. Chile was chosen because it is nascent in its solar desalination pilot plants utilizing photovoltaics and solar thermal technology. Lastly, Ghana was chosen to illustrate how rural and remote regions can adopt hybrid water systems since it has a greater need for water and electricity than the other three countries.

4.2 Key variables for the four regions

The specifications for ranking the feasibility of solar-powered water purification and solar desalination for each region was based on multiple variables [5]. These variables consist of economic, political, demographics, and water resources and are summarized in Table 4. Stark comparisons can be seen between urban modern Singapore and rural Ghana in terms of political stability and total population. The World Bank ranked political stability on a scale of -2.5 (weak) to 2.5 strong. Singapore outshined Oman, Ghana, and Chile with political stability and government effectiveness. Chile has about three times the population of Singapore, but Ghana has the highest population, 25,366, of the four countries. All countries have a relatively high literacy rate which was used to determine the ease of information transfer in terms of business and technology of water purification systems [5]. Ghana has nearly half their population living in rural regions

(47%), followed by Oman has a 23% of their population living in rural areas whereas Singapore has no rural regions. All countries have high literacy rates over 91% or higher. Oman has an average household size of 7.5 and uses the most water per capita 180m³/year.

Table 4. Socio-economic data for the three regions

Variables	Singapore	Oman	Chile	Ghana
GDP per capita (\$US)	56,286	19,309	14,528	1,442
Gross domestic product growth (%)	2.9	3.9	1.9	4.0
Political stability (% ranking)	1.33	0.49	0.37	0.02
Government effectiveness (% ranking)	100	64	84	56
Total population (thousands)	5,411	3,632	17,619	25,366
Percentage rural (%)	0	23	11	47
Literacy rate (% population over age 15)	96.8	91	97.5	77
Average household size (# persons)	3.5	7.5	3.7	4
Water use per capita (m ³ /year)	150	180	85	48
% of urban population with access to improved water	100	96	100	93
% of rural population with access to improved water	0	80	93	84
Average solar irradiance (daily)	4.56 kWh/m ² /day	5,500-6,000 kWh/m ² -day	5,500 kWh/m ² -day	5.524 kWh/m ² -day

Sources: The World Bank, CIA Factbook.

4.3 Background of Singapore's water efficiency scheme

Singapore's water shortage has spurred the development of a robust, sustainable water supply based on four sources of water supply, also known as the 'Four National Taps.' Singapore's water agency the Public Utility Board (PUB), developed a long term plan to secure the nation's water supply. Singapore's diversified supply of water is comprised of (1) local catchment water, (2) imported water, (3) highly-purified reclaimed water known as NEWater, and (4) desalinated water [6].

Singapore collects rainwater and storm-water through a comprehensive network of drains, canals, rivers, reservoirs, and storm-water collection ponds. The water is then treated. This paper focuses on local catchment of Singapore's surface water because it is less utilized than the other three 'national taps'. Currently, Singapore is aiming to lessen its reliance on imported water and increase their reliance on desalination water and recycled water. Secondly, Singapore has been importing water from Johor, Malaysia, under two bilateral agreements. The final agreement will expire in 2061. This has led the country to focus on self-sufficiency by way of NEWater, a high-grade reclaimed water produced from treated used water that is further purified using advanced membrane technologies and ultra-violet disinfection. Singapore is striving to raise the NEWater capacity to meet 55% of the their future water demand [6]. Currently, desalinated water with a total capacity of 100 million gallons of water a day from two plants can meet up to 25% of Singapore's current water demand. By 2060, Singapore's Government's estimates that its water needs will be about double the current 400 million gallons a day, that it will need and that it can meet 80 percent of its water demand through treated seawater and NEWater.

4.4 Optimization and performance of an off-grid solar-powered water purification system

In Southeast Asia there are countries with intermittent electricity and high chances of typhoons that can cause blackouts. This project kept in mind emergency relief options by using photovoltaics, not grid electricity, as the main power source. The system was implemented in Singapore, but has been designed for Southeast Asian regions with limited to no electrical grid connections, such as Myanmar. We conduct an experimental study on the utilization of photovoltaics to purify rainwater and generating electricity that can be stored in a battery. The objective of this project is to test the feasibility and application of a stand-alone water purification hybrid unit that would treat storm water and rainwater to meet Singapore's PUB drinking water standards.

4.5 Materials and Methods

Selecting the appropriate water filtration system to augment Southeast Asian water distribution systems was a key factor in the specific location and to meet the needs of Singapore. The constraints for the off-grid system were cost-efficiency, ability to provide safe drinking water to villages in Southeast Asia, compliance with the World Health Organization (WHO) drinking water standards, and low maintenance. A wide range of design options for household treatment exists, including sand filtration, various types of membrane filtration, and disinfection alternatives.

4.5.1 Photovoltaics

Photovoltaics (PV) are a promising renewable energy for Southeast Asia and other areas with strong and abundant sunlight. Locations that have plenty of sunlight year-round and have no existing infrastructure make photovoltaics particularly attractive. Sunlight in Singapore has an average solar irradiance of 1600 kWh/m²/year. In remote locations without infrastructure, photovoltaics are especially favorable and maybe the only means for electricity. Photovoltaics also meet the two project's environmental constraints: to ensure that the electricity source causes no emissions and requires no imported fuels.

4.5.2 Study Site

The system was constructed at the Kent Ridge Park in Singapore. The influent water was obtained from a pond located in the park, which serves as part of a drainage system. Run-off in the vicinity was directed to and temporarily stored in the pond. The pond covers an area of about 6600 square meters, with a depth varying from 0.3 meters to 5 meters. The pond served as temporary storage for runoff and the water quality varied throughout the experiment run-time. The experiment spanned the monsoon and dry seasons in Singapore. The water quality of the pond is shown in Table 2.

4.5.3 System configuration and operation

Microfiltration coupled with ultraviolet light powered by photovoltaics (solar panels) were chosen for development. A microfiltration system was used for organics removal for the treatment of pond water to meet safe drinking water standard. In Figure 4, a diaphragm pump was used to feed the lake water into the feed tank. The feed tank had a

working volume of 200 L and a 0.5- μm pore size ceramic flat sheet microfiltration membrane (Ceraflo, Singapore) module with a surface area of 4 m².

Filtration was gravity-driven using the water head difference between the submerged membrane and the tank water level. A level sensor was installed in the feed tank to maintain the water head required to drive the filtration. The filtrate then flowed to the activated carbon filter column, which was packed with 8 mesh (2.36 mm) granular activated carbon (GAC 830W, Norit, USA) [13]. The treated water was disinfected using solar-powered inline ultraviolet (UV) light using a wavelength of 254 nm for disinfection. The product water was then collected for analysis.

A 90 W, 12V solar panel (Kamtex, Singapore) provides all electrical power. A CA-08 charge controller and a pre-assembled control board were assembled to control the power output to the UV contactor and diaphragm pump. A three-day battery backup was included in the system.

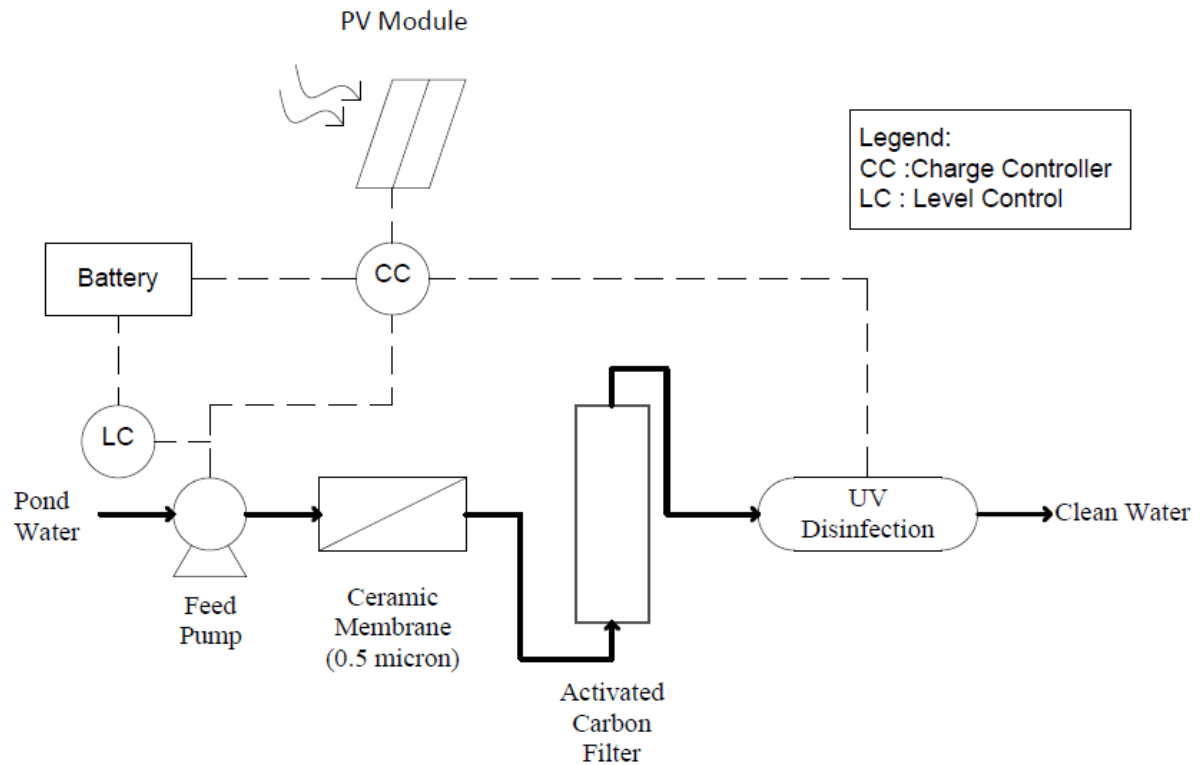

Figure 4. Schematic diagram of the experimental setup.

4.5.4 Analytical Methods

Influent and effluent samples were taken once a week from the feed tank and UV disinfection reactor effluent for analysis. The samples were filtered using a 0.45- μm membrane filter (Supor 450 Membrane Disc Filters, Pall Co., USA), and UV effluent was then analyzed for dissolved organic carbon (DOC), total nitrogen (TN), cations and anions. The DOC and TN were analyzed by a TOC/TN analyzer (TNM-L/TOCL-CSH, Shimadzu, Japan). Cations and anions were measured using ion chromatography (LC20 Chromatography Enclosure, DIONEX) and ion chromatography (ICS-1600, DIONEX), respectively. Conductivity and pH values were measured using an Ultrameter (6PFC^E,

Myron L, USA). Turbidity was analyzed using a laboratory turbidimeter (2100 Series, Hach, Germany).

E. coli analysis was performed by Analytical Laboratories (Singapore) Pte. Ltd, an accredited laboratory in Singapore. Samples were taken in sterile containers and immediately sent to the laboratory for analysis. The analysis was done in accordance with the Standard Method, 9221F.

4.6 Costs

Reviews of existing treatment systems show that the highest operation and maintenance costs at water treatment plants are for labor, energy, and chemicals. In this study, the findings show that operational costs were \$3500/yr and maintenance costs were nearly \$500/yr. The off-grid PV system using mono-crystalline silicon modules produced savings in both areas, but the majority of the savings occurred because those areas did not need an outside source of electricity. Maintenance of the design is minimal and we only performed a bi-weekly inspection and cleaning of the pump. The system capital costs are approximately SGD 3,500. This included the contractor fees, photovoltaic panels, tank, level controller, battery, piping, pump, activated carbon, UV disinfection contactor, and transportation costs.

4.7 Results and Discussion

4.7.1 General Parameter and Ions

The pond water quality and treated water quality is shown in Table 2. As the Kent Ridge Park pond served as rainwater runoff storage, the pH and conductivity of the influent water was within acceptable limit by the USEPA and WHO. Due to the lack of agricultural activity in the vicinity, the TOC, nitrite and nitrate concentration of the influent were within the guideline's limits. Fertilizers are usually used in agricultural sites. Thus, surface runoff from agricultural sites will result in an elevated concentration of nitrate and nitrite. The TOC and nitrate concentration of the effluent were 0.29 mg/L and 0.19 mg/L, respectively.

During the start of the experiment, it was the monsoon season in Singapore. When the experiment ended in March, it was the dry season in Singapore. Total rainfall in December 2014 was 245.6 mm [7], 161.9 mm higher than that in January 2015. Greater rainfall resulted in higher turbidity, as the settled particles were re-suspended into the water bodies. Greater rainfall also resulted in greater soil runoff, increasing the turbidity of the water bodies. The difference in rainfall resulted in large variation in turbidity values, accounting for the high standard deviation in turbidity of the influent. After filtration, turbidity dropped from an average of 11.87 NTU to 2.71 NTU. The turbidity of the effluent was due to wash-off of the activated carbon from the activated carbon column.

E. Coli is often used as an indicator organism in the influent water. Presence of *E. Coli* in source water indicates the presence of fecal contamination [8]. Fecal contamination often

results in diarrhea and other diseases. After treating, the water effluent did not have any presence of *E. Coli*.

Table 4.1. Average Water Quality of Kent Ridge Park Pond Before and After Treatment Compared to Environmental Protection Agency (EPA) and World Health Organization (WHO) standards.

PARAMETERS	INFLUENT	EFFLUENT	US EPA	WHO [10]
pH	7.39 ± 0.3	8.42 ± 0.5	6.5 – 8.5	6.5 – 8.5
Conductivity (µS/cm)	182 ± 15	243 ± 24	n/a	938*
Turbidity (NTU)	11.87 ± 13.47	2.71 ± 2.46	n/a	< 5
TOC (mg/L)	2.38 ± 1.3	0.29 ± 0.3	2.0	n/a
NO ₂ ⁻ (mg/L)	n.d.	n.d.		3
NO ₃ ⁻ (mg/L)	0.88 ± 0.14	0.19 ± 0.14		50
<i>E. Coli</i> (CFU/100mL)	23 ± 13	0 ± 0	below analytical detection	below analytical detection

* Conductivity is derived from total dissolved solid

The effluent parameters were compared to the World Health Organization (WHO) and Environmental Protection Agency (EPA) water quality standards. The EPA established National Primary Drinking Water Regulations (NPDWR) that set mandatory water quality standards for drinking water contaminants. Some of the contaminants that were tested are not a threat to health.

After microfiltration, turbidity and *E. Coli* were treated to drinking water standards. The hardness level in the effluent increased (Table 4). Ion concentration for cations decreased for sodium, increased for potassium, and increased for magnesium. Ion removal may have occurred due to membrane absorption.

Table 4.2 Ion concentrations of the influent and effluent water.

		INFLUENT	EFFLUENT
Cations (mg/L)	Na ⁺	8.72 ± 5.21	6.81 ± 5.77
	K ⁺	9.53 ± 2.31	9.87 ± 2.24
	Mg ²⁺	0.38 ± 0.18	1.40 ± 1.14
	Ca ²⁺	20.53 ± 3.07	23.16 ± 2.40
Anions (mg/L)	F ⁻	n.d.	n.d.
	Cl ⁻	6.58 ± 0.35	3.96 ± 1.94
	NO ₂ ⁻	n.d.	n.d.
	NO ₃ ⁻	0.88 ± 0.14	0.19 ± 0.14
	SO ₄ ²⁻	8.26 ± 5.51	4.07 ± 3.22

4.7.2 MS2 bacteriophage virus removal

In this study, virus removal of the system was stimulated using the MS2 bacteriophage virus. MS2 virus was added into the system and effluent at a different stage of the system was collected for MS2 virus detection. Table 4 tabulates the concentration of MS2 virus and log removal at a different stage of the system.

Table 4.3 Bacteriophage MS2 log removal in different parts of the system.

	Raw Water	Filtered Effluent	Activated Carbon Effluent	UV Effluent
MS 2 Count (CFU/100mL)	2.1×10^5	2.73×10^5	1.07×10^5	1.35×10^2
Removal as compared to prior parameter	-	below analytical detection	0.293	2.99

(log removal)

Removal as
compared to raw
water
(log removal)

-

below
analytical
detection

0.293

3.19

From Table 4.2 it is observed that the membrane used in this system was unable to remove MS2 viruses. The pore size of the membrane was 0.5 μm , which is larger than the MS2 virus (0.025 nm in diameter). This was similar to a study by J.G. Jacangelo which showed that a microfiltration filter was only able to achieve 0.3 – 1.2 log removal [8].

Activated carbon was only able to achieve 0.293 log removal of the MS2 virus. Granular activated carbon was able to remove virus through both adsorption and filtration. A similar study [13] had shown that the use of GAC was able to achieve 0.3 – 1 log removal for MS2 virus.

The majority of the MS2 virus removal was achieved using the UV contactor at the end of the system. The UV reactor was able to provide 2.99 log removal of the MS virus. In total, the system was able to provide 3.19 log removal of the MS2 virus.

4.8 Experimental Limitations

The system operated intermittently after storms. Also, the level controller failed twice during the first four months of operation. However, the most problematic function of the treatment resides in the pump, which would clog periodically. In order to maintain a reliable pump, a recurrent cleaning schedule is required. In short, it is without question

that there is a need for more data and that the system should function during longer periods of time.

In addition, a system that is affordable and cost-effective for developing countries can be achieved through locating and utilizing building parts and materials from areas that trade at an economical rate. Still, there is a need for more reliable costs, a maintenance schedule, and training for locals to clean and maintain the membrane and pump regularly. Furthermore, if this unit is distributed to rural countries, locals may be able to produce activated carbon to reduce cost.

The work described in this section is a small step towards further research that can be conducted for small-scale, solar-powered water purification. The lack of adequate clean water and sanitation standards are prevalent global issues that need to be addressed beyond Southeast Asia.

4.9 Case studies for desalination in Oman and Ghana

4.9.1 Desalination in Oman

The most prolific users of desalinated water are in the Arab region, specifically, Oman, Saudi Arabia, Kuwait, United Arab Emirates, Qatar, and Bahrain [22]. Renewable desalination is growing in arid regions such as the MENA region. The world's largest solar PV desalination plant is located in Al Khafji, in Saudi Arabia. Oman is a fast-growing growing country with the fifth largest economy in the Gulf Cooperation Council region. With its limited water sources, Oman is highly dependent on large-scale desalination. Currently, Oman has seven large plants, of which five are combined power

and desalination plants, and the remaining two are stand-alone plants producing only water. According to Oman Power and Water Procurement Co. (OPWP) water demand will increase with 8% per year until 2019. It has a dependence on desalination, however it is exploring other options including renewable energy and forward osmosis (FO) desalination. Oman's government turned to water-resource management by constructing dams [10].

Three technologies that potentially can reduce the energy requirements of desalination by up to 30 percent are forward osmosis, carbon nanotubes, and biomimetics. The most marketable of the three technologies is FO. In 2009 plant located at Al Najdah in the Al Wusta region of Oman. This plant is a 200m³/d FO commission by Modern Water. FO draws water through the porous membrane into a solution that contains higher salt concentration than seawater, but a special kind of salt that is easily evaporated. Unlike reverse osmosis, in which the seawater is directly desalinated by being pressurized and driven through a membrane that only allows water to pass through.

Forward Osmosis advantages:

- Natural process requires little or no electricity or external power source.
- FO overcomes fouling limitations in pressure driven membrane allowing proper filtration of difficult products.
- FO can process feed streams; high levels of suspended solids.
- Suited to alternate applications, such as the production of hydration drinks – where a concentration sugar syrup is diluted to a desirable level

However, a recent study from Massachusetts Institute of Technology (MIT) found that contrary to popular belief, FO desalination seawater is significantly less energy efficient, compared to RO [13]. This paper focuses on desalination by solar power because of the

continual availability of sun-light, general convenience and ease of maintenance, and reduced adverse environmental effects [14].

Oman has a high availability of sunshine, which makes solar desalination an attractive alternative to conventional sources [14]. Solar irradiation levels in Oman are among the highest in the world with energy density available in all regions [15, 16]. Wind energy is also high in Oman with potential harnessing in coastal areas in the mountains north of Salalah. A barrier for renewable energy adoption is the highly subsidized and cheap natural gas electricity. Currently, solar PV and wind energy are seen as having economic potential to thermal electricity in rural regions [15, 16].

4.9.2 The complications of financing Ghana's first desalination plant

Ghana has been struggling its first desalination plant, which opened in 2015. Located in Nungua, the plant pumps 13.2 million gallon of fresh water daily from treated seawater to supply water to 500,00 residents. The project costs estimated \$179M and was financed by the Multilateral Investment Guarantee Agency (MIGA), the political risk insurance arm of the World Bank Group. The project is a Public Private Partnership (PPP) between the Government of Ghana and the Stanbic Bank. The project will be managed for 25-years before it will be transferred to Ghana Water Company (GWC). Within a few months of the opening of the Teshie-Nungua Desalination Plant, the government postponed the commission due to users complaints about the salty taste of the water [17].

Another obstacle with the new desalination plant is in governance. There is a lack of transparency in the water purchase agreement between Ghana's supplier, GWC, and the

Korean firm BEFESA Desalination Developments Ghana that constructed the project for US\$110 million. The problem is that the Public Utility Workers Union (PUWU) states that the current agreement is unfair to GWC and only benefit BEFESA. The union says that the bad contract will not allow GWC to make any profit. With a power bill for the plant of GH¢1.3 million (US\$ 300,000) a month, GWC is, according to the union, losing some GH¢ 3.39 /m³ (US\$ 1.65 /m³) from the BEFESA deal [18].

4.9.3 Comparative economics of solar powered RO plants for water-stressed countries

Desalination techniques can be classified into two main categories [22]:

- Phase-change, or thermal processes – where base water is heated to boiling. The main thermal desalination processes are multi-stage flash (MSF) distillation, multiple-effect distillation (MED), and vapor compression (VC), which can be thermal (TVC) or mechanical (MVC).
- Membrane or single-phase processes – where salt separation occurs without phase transition. The main membrane processes are reverse osmosis (RO) and electrodialysis (ED).

Renewable desalination is mostly based on the RO process (62%), followed by thermal processes such as MSF and MED. Photovoltaics is the dominant energy source, followed by solar thermal, and wind energy.

The cost of water desalination varies depending on water source access, source water salinity and quality, specific desalination process, power costs, concentrate disposal method, project delivery method, and the distance to the point of the use. [22] The most obvious environmental benefits from using renewable energy sources in water

desalination are that they do not contribute to global warming or greenhouse gas emissions. Additionally, utilizing renewables in remote, off-grid areas can be the only option. This can also foster socioeconomic development.

The process of choosing the appropriate renewable energy desalination technology depends on a number of factors, namely, plant size, feed-water salinity, remoteness, availability of grid electricity, technical infrastructure, and the type of potential of the local renewable energy resources. It is with the utmost importance to properly select standalone power-supply desalination systems in order to provide a reliable supply of power and water at a reasonable cost. Figure 4 shows the possible combination of renewable energy systems with desalination units.

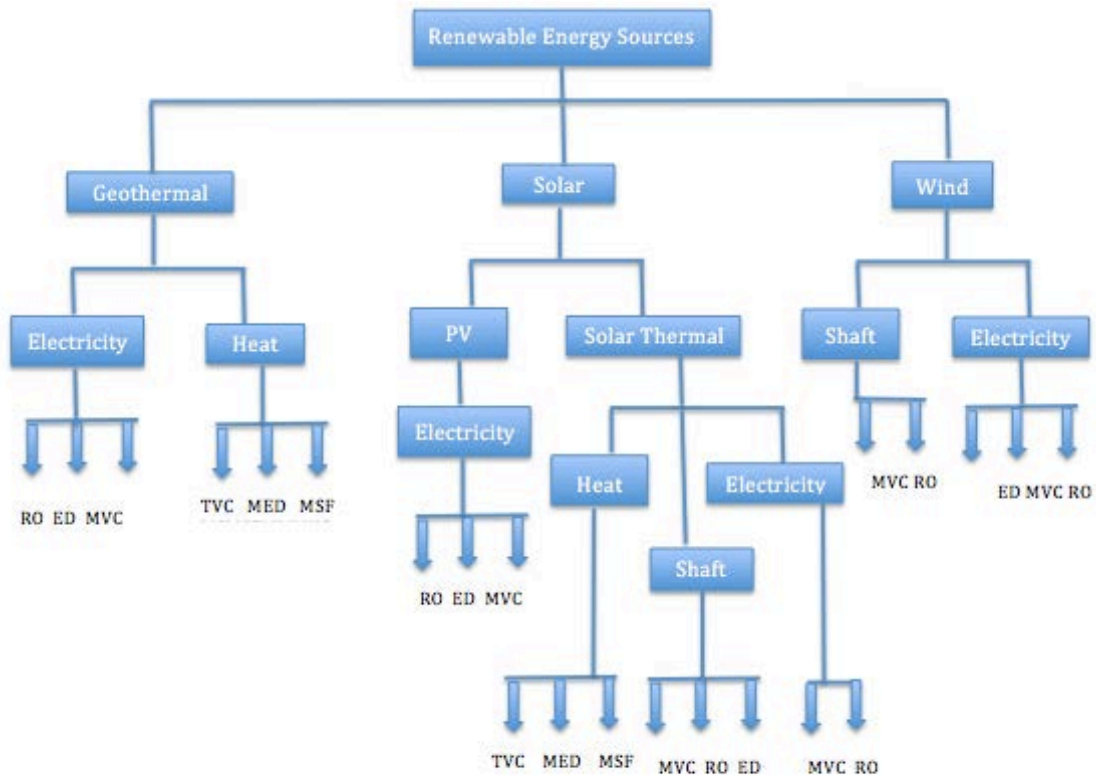

Figure 4.1 Possible combinations of renewable energy desalination systems.

Solar thermal, solar PV, wind, and geothermal technologies could be used as energy supplier for desalination systems. Table 4.4 presents the most promising combinations of renewable energy resources with desalination technologies [22].

Table 4.4 Renewable Energy Coupling Options

RE Resource	Desalination Process				
	MSF	MED	VC	RO	ED
Solar thermal	X	X			

Solar PV				X	X
Wind			X	X	X
Geothermal	X	X	X	X	X

One of the main barriers to renewable energy desalination is the cost. The current cost of a desalination process is still high because of its extensive use of energy. Despite the free cost of renewable energy resources, their capital costs are expensive. Therefore we decided to compare the cost distribution of both conventional and renewable energy-operated desalination units [22].

4.10. Renewable energy hybrids

Studies have concluded that renewable-energy powered systems could compete with conventional systems under certain circumstances [22]. Several studies on a suitable match between renewable energy resources and desalination processes propose that solar thermal/MED, solar thermal/MSF, solar PV/RO, solar PV/ED, wind/RO, and geothermal/MED technologies are very promising options (see Table 4.3). There is uncertainty in solar thermal/MED and solar thermal/MSF as they have been theoretical studies [22].

Table 4.5 Processes and their percentage costs

Type of Process	Capital Costs (%)	Operational Costs (%)	Energy Costs (%)
Conventional (RO)	22-27	14-15	59-63

Conventional (MSF)	25-30	38-40	33-35
Renewable	30-90	10-30	0-10

This paper has focused on PV-RO desalination plants in Singapore, Oman, and Ghana. Seawater desalination via MSF consumes typically 80.6 kWh of heat energy (290 MJ thermal energy per kg) plus 2.5 to 3.5 kWh of electricity per m³ of water, while large scale RO requires only about 3.5 to 5.0 kWh of electricity per m³. The cost of desalination has been decreasing over the last year down to the USD 0.5/m³.

As a general rule, seawater RO unit has low capital cost and significant maintenance due to the high cost of the membrane replacement [22]. The major energy requirement for RO desalination is for pressurizing the feed water. Literature shows that the water cost of a PV seawater RO unit ranges from 7.98 to 29 US\$/m³ for product-water capacity of 120-12m³/day, respectively. [22] In comparison, the water cost of a PV-operated ED unit ranges from 16 to 5.8 US\$/m³. Wind energy could be used to drive RO, ED, and VC desalination units. The estimated water cost produced from the installed wind/RO unit ranges from 7.2 to 2.6 US\$/m³ of fresh water.

4.11 Results and Discussion

4.11.1 Policy overview and recommendations

Wide ranges of policy tools are designed to provide incentives for voluntary investments in renewable energy by reducing the costs. Renewable energy policies can be grouped into three main categories: (1) price-setting and quantity-forcing policies, which mandate

prices or quantities (2) investment cost reduction policies, which provide incentives in the form of lower investment cost; and (3) public investments and market facilitation activities [19]. In the past years Oman has attracted private investors for energy and water production by offering private purchase agreements (PPAs). To finance large solar desalination projects PPAs could also be used to integrate with tendering to ensure the lowest possible electricity rates [16]. Standard PPAs could drive small and medium-sized projects. According to IRENA, the feed-in-tariff (FIT) can be used to accelerate investment in solar technologies. FITs have been the main instrument to promote deployment of PV. Implementing a feed-in system in the form of a premium on top of electricity market prices can be used to expose technologies to competition (IEA, 2011).

4.11.2 Fiscal Incentives

The following section discusses fiscal incentives and regulatory approaches for renewable energy policies. Each of the four countries we assessed has their own barriers to market adoption. For example, in Ghana it is the lack of technical and commercial skills and information. Table 4.5-4.7 from Mitchell et al. (2011) lists support policies that work, but will have varying levels of impacts based on each individual country.

Table 4.6 Fiscal Incentives to Encourage Deployment of Renewable Desalination Technology

Policy	Definition
Fiscal Incentives	
Grant	Monetary assistance that does not have to be repaid and that is bestowed by a

	government for specified purposes to an eligible recipient. Grants help reduce system investment costs associated with preparation, purchase or construction of renewable energy (RE) equipment. In some cases, grants are used to create concessional financing instruments (e.g., allowing banks to offer low-interest rates for RE systems).
Energy production payment	Direct payment from the government per unit of RE produced.
Rebate	One-time direct payment from the government to a private party to cover a percentage or specified amount of the investment cost of a RE system or service. Typically offered automatically to eligible projects after completion, not requiring detailed application procedures.
Tax credit (production or investment)	Provides the investor or owner of qualifying property with an annual income tax credit based on the amount of money invested in that facility or the amount of energy that it generates during the relevant year. Allows investments in RE to be fully or partially deducted from tax obligations or income.
Tax reduction/exemption	Reduction in tax, values-added, energy or carbon tax – applicable to the purchase (or production) of RE

Source: Mitchell et al. (2011)

Table 4.7. Public finance to Encourage Deployment of Renewable Desalination Technology

Policy	Definition
--------	------------

Public finance	
Investment	Financing provided in return for an equity ownership interest in a RE company or project.
Guarantee	Risk-sharing mechanism aimed at mobilizing domestic lending from commercial banks for RE companies and projects that have perceived credit risk.
Loan	Financing provided to a RE company or project in return for a debt obligation.
Public procurement	Public entities preferentially purchase RE services (such as electricity) and/or RE equipment.

Source: Mitchell et al. (2011)

Table 4.8. Regulations to Encourage Deployment of Renewable Desalination Technology

Quantity Driven	
Renewable Portfolio Standard/Quota obligation or mandate	Obligates designated parties (generators, suppliers, consumers) to meet minimum RE targets, generally expressed as percentages of total supplies or as an amount of RE capacity, with costs borne by consumers.
Tendering/Bidding	Public authorities organize tenders for given quota of RE supplies or supply capacities, and remunerate winning bids at prices mostly above standard market prices.
Price-driven	
Fixed payment feed-in tariff (FIT)	Guarantees RE supplies with priority access and dispatch, and sets a fixed price

	varying by technology per unit delivered during a specified number of years.
Premium payment FIT	Guarantees RE supplies an additional payment on top of their energy market price or end-use value.
Quality-driven	
Green energy purchase	Regulates the supply of voluntary RE purchases by consumers, beyond existing RE obligations.
Green labelling	Government-sponsored labeling that guarantees that energy products meet certain sustainability criteria to facilitate voluntary green energy purchasing.
Access	
Net metering (net billing)	Allows a two-way flow of electricity between the electricity distribution grid and customers with their own generation. The meter flows backwards when power is fed into the grid.
Priority or guaranteed access to network	Provides RE supplies with unhindered access to established energy networks.
Priority dispatch	Mandates that RE supplies are integrated into energy systems before supplies from other sources.

Source: Mitchell et al. (2011)

4.12 Conclusions

This paper considers the potential synergies between renewable powered desalination.

There is increasing evidence that in rural areas of hot and arid tropics, the system (panel)

degradation is very fast --soiling, very high temperatures. Worldwide, the experience shows that renewable desalinated water could be very cheap in coastal areas, wherein the heat produced in nuclear plant is used for producing steam from brine in the multi stage flash distillation process. The solar PV systems are very expensive, and their maintenance is even more difficult in rural areas.

One challenge for renewable energy adoption is finding policies to fit rural and urban areas of the same country. Not all policies are fairly designed and in some cases like in Ghana, developers can reap more benefits than they ought to. Among policy types, FITS are widely accepted and easier to implement. The problem lies in setting an appropriate tariff levels. Policies that work in the Oman won't necessarily work in Singapore or Ghana, vice versa. Our assessment of four countries research has led us to develop broad recommendations listed below. The government in Singapore is the most mature in its deployment of renewables, specifically PV technology. We suggest they utilize the following recommendations for Singapore to take advantage of the momentum of solar PV adoption.

- Recognize desalination for water generation is a viable solution but continue to invest in renewable purification technology for surface water and storm water.

Governments like Oman, Chile, and Ghana that are not yet committed to large-scale RE deployment should consider three critical factors:

- Accelerate the momentum of deployment by devising renewable desalination strategies at the national and international level with government and agencies.

- Reference international mechanisms, such as those provided by the Clean Energy Ministerial and G20 for concerted efforts to develop a broad range of renewable energy technologies [20].
- Cooperate with governments that are mature in RE deployment to share policy experience and allow refinement and dissemination of best practice in policy development.

In summary, addressing the worldwide challenges of freshwater supply will require novel water management strategies together with major investments in infrastructure and innovative technologies. In this study, we constructed off-grid solar water purification systems in Singapore to assess the feasibility of introducing it into the market. Next, we assessed case studies for Oman and Ghana. Desalination cost has decreased over the last years due to technical improvements. The addition of coupling renewable energy sources can be even more expensive if there is a lack of subsidies and policies in place.

Developing nations will continue to grapple with cost-effective solutions and socio-economical-political issues as it relates to clean water attainment. Thus, with governmental and non-profit organizational cooperation and guidance in financing, countries will be able to utilize the techniques of water conservation, resource management, sustainable energy sources such as solar to help confront these complex and crucial water issues.

r crisis needs a holistic approach because a variety of water filtration technologies are needed to confront the diverse and complex nature of Ghana's water dilemma. On-site,

5. Conclusions and Remarks

The motivation of this dissertation is to provide the reader with realistic approaches and understanding of the financial constraints and political barriers of adopting water purification technology in regions that are rural, off-grid, and have no access to electricity sources or sanitation systems. A variety of technologies exist that can provide solutions to rural Ghana. As evident in Chapter 2, Ghana's water personal, and community water purification technologies were evaluated based on the following criteria: effectiveness, capital cost, operating cost, energy consumption, environmental impacts, and waste generation. Effectiveness was considered to be the most important of the criteria. A table was developed based on a 30-day field study. Of the technologies the LifeStraw[®] and kosim water filter are immediately available and required no training.

Chapter 3 describes the Greater Mekong Sub-region of Southeast Asia, a region afflicted with inadequate access to clean water and unreliable electricity. Some regions have an abundance of sunlight, wind, and biomass to utilize as a primary energy source. A proposed desalination system powered by solar panels was modeled to evaluate the cost-effectiveness of a stand-alone, small-scale renewable energy powered sea-water reverse osmosis system for the Greater Mekong Sub-region. A new energy optimization methodology was introduced to simulate daily power production from renewable energy sources: biofuel, geothermal, wind, and solar. In Myanmar, solar power is costly and currently an option only for rural and off-grid applications. The model showed wind

power desalination is the least expensive more than solar photovoltaics at 0.50\$/m³ and 1/m³, respectively.

In Southeast Asia there is great risk of typhoons that can cause blackouts. In recent years, countries such as Nepal and Thailand have experienced massive storms and flooding that led to landslides, intermittent electricity, and poor water quality. On the other hand, Singapore is a model for water technology, specifically water reuse and desalination. Chapter 4 describes an off-grid water purification we developed to ameliorate lack of potable water during times of emergencies. Photovoltaics are a promising renewable energy sources for Southeast Asia as shown in the background of Chapter 4. The simple, off-grid system was constructed in Singapore with applications to neighboring countries. The cost for the system remained below \$2K (USD), which would still be too high for rural communities in Southeast Asia to afford without the help of subsidies, grants, etc.

The final chapter provides a roadmap for financing Asia's infrastructure, specifically water. International investment communities, such as bank and funding agencies have provided monetary and technical support to novel, high-risk projects. Our study concluded that the growing need for infrastructure depends on four factors: 1. Water governance, 2. Multilateral financing, 3. Public-private-partnerships, and 4. Cost-recovery pricing.

References

1. Forstmeier, M., Feichter, W., & Mayer, O. (2008). Photovoltaic powered water purification – challenges and opportunities. *Desalination*, 221, 23–28. <http://doi.org/10.1016/j.desal.2007.04.063>
2. K. Reiche, A. Covarrubias, and E. Martinot. (2000). Expanding Electricity Access to Remote Areas : Off-Grid Rural Electrification in Developing Countries. *World Bank*, 52–60.
3. Food Agricultural Outlook (FAO), 2005. UNEP Geo Data Portal, Available at: [/http://geodata.grid.unep.ch/S](http://geodata.grid.unep.ch/S).
4. World Resources Institute, 2013
5. Johnson, D. M., Hokanson, D. R., Zhang, Q., Czupinski, K. D., & Tang, J. (2008). Feasibility of water purification technology in rural areas of developing countries, 88, 416–427. <http://doi.org/10.1016/j.jenvman.2007.03.002>
6. PUB, Singapore’s national water agency. <http://www.pub.gov.sg/consERVE/Pages/default.aspx>
7. National Environmental Agency, Singapore (2015) Daily values of Meteorological elements in 2014.
8. J.G. Jacangelo, S.S. Adham & J.M. Laine (1995) Mechanism of Cryptosporidium, Giardia, and MS2 virus removal by MF and UF. *J. Am. Water Works Assoc.*, 87 (9), 107-121.
9. E. Paramonova, E.L. Zerfoss & B.E. Logan (2006) Measurement of Biocolloid Collision Efficiencies for Granular Activated Carbon by Use of a Two-Layer Filtration Model, *Applied Environmental Microbiology*, 72(8), 5190 – 5196.
10. Al-Ismaily, H., & Probert, D. (1998). Water-resource facilities and management strategy for Oman. *Applied Energy*, 61(3), 125–146. [http://doi.org/10.1016/S0306-2619\(98\)00026-9](http://doi.org/10.1016/S0306-2619(98)00026-9)

11. Luo, T., R. Young, P. Reig. (2015). Aqueduct Projected Water Stress Country Rankings, (August), 1–16.
12. P. Reig, A. Maddocks and F. Gassert. The World’s 36 Most Water Stressed Countries.” World Resources Institute, 2013. <http://www.wri.org/blog/2013/12/world’s-36-most-water-stressed-countries>
13. McGovern, R. K., & Lienhard V, J. H. (2014). On the potential of forward osmosis to energetically outperform reverse osmosis desalination. *Journal of Membrane Science*, 469, 245–250. <http://doi.org/10.1016/j.memsci.2014.05.061>
14. Al Suleimani, Z., & Nair, V. R. (2000). Desalination by solar-powered reverse osmosis in a remote area of the Sultanate of Oman. *Applied Energy*, 65(1-4), 367–380. [http://doi.org/10.1016/S0306-2619\(99\)00100-2](http://doi.org/10.1016/S0306-2619(99)00100-2)
15. The World Bank. (2012). *Renewable Energy Desalination An Emerging Solution to Close the Water Gap in the Middle East and North Africa*. <http://doi.org/10.1596/978-0-8213-8838-9>
16. International Renewable Energy Agency. (2013). Renewables Readiness Assessment, 1–72.
17. Assan, Kofi. “Launch of Teshie-Nungua desalination project postponed.”<http://myjoyonline.com/news/2015/February-20th/launch-of-teshie-nungua-desalination-project-postponed.php>
18. “Ghana union calls for review of Teshie-Nungua water purchase deal.” http://www.desalination.biz/news/news_story.asp?id=8194
19. Beck, F., & Martinot, E. (2004). Renewable Energy Policies and Barriers. *Encyclopedia of Energy*. <http://doi.org/10.1016/j.enpol.2004.08.032>
20. International Energy Agency. (2012). Measuring progress towards energy for all. *World Energy Outlook 2012, Chapter 18*, 529–548.
21. Mitchell, C., et al. (2011), “Chapter 11: Policy, Financing and Implementation,” in IPCC Special Report on Renewable Energy Sources and Climate Change Mitigation, Cambridge University Press, Cambridge and New York, pp. 865-95
22. Al-Karaghoul, A., & Kazmerski, L. (2011). Renewable energy opportunities in water desalination, Desalination trends and

